



PARTS CATALOGUE

WR450F'08 (5TJM) OCEANIA,SOUTH AFRICA

WR450F
PARTS CATALOGUE
©2007 by Yamaha Motor Co., Ltd.
1st edition, September 2007
All rights reserved.
Any reprinting or unauthorized use
without the written permission of
Yamaha Motor Co., Ltd.
is expressly prohibited.
Printed in Japan.

A3

FOREWORD

This Parts Catalogue is related to the parts for the model(s) on the cover page. When you are ordering replacement parts, please refer to this Parts Catalogue and quote both part numbers and part names correctly.

1. Modifications or additions which have been made after the issue of the Parts Catalogue will be announced in the Parts News.

It is advisable that you make the necessary corrections to the Parts Catalogue according to the Parts News.

2. Abbreviations

The following abbreviations are used in this Parts Catalogue.

“UR” Use specified parts number.

“UN” Use as many as needed.

“AP” Alternate Parts

“LM” Locally Made (Parts need to be ordered locally)

“F#” Frame No. (Applicable machine No.)

“O/S” Over Size

3. The number of components for assembly

- Parts, which are to be supplied in an assembly, are listed with a dot (.) in front of the part name as shown below.
- The numeral appearing to the right of each component part indicates the quantity of parts for each assembly unit.

PART NO.	DESCRIPTION	Q'TY	REMARKS
2F5-83310-60	FRONT FLASHER LIGHT ASSY	2	
115-83311-60	.BULB (6V-18W)	1	

4. Applicable colours of graphics are represented in the “REMARKS” as shown below.

PART NO.	DESCRIPTION	Q'TY	REMARKS
2N4-24110-00-X5	FUEL TANK COMP.	2	MXR
3J1-24240-10	.GRAPHIC, FUEL TANK	1	FOR MXR

5. Note that the illustrations for reference in finding parts numbers are not to be used for assembling. When assembling, please use the applicable service manual.

6. The asterisk (*) before a reference number indicates modified items after the first edition.

FOREWORD

7. Applicable Serial No.

Engine Serial No.

Frame Serial No.

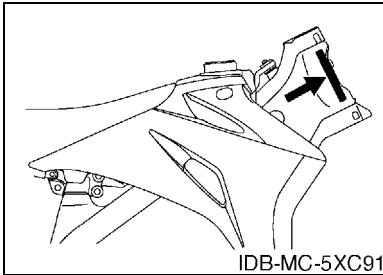
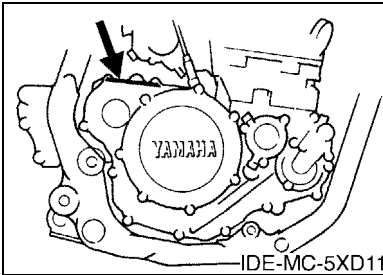

8. Applicable Colour Code (The (*) mark shows Model colour.)

Abbreviation	Colour Name	Colour Code
DPBSE(*)	DEEP PURPLISH BLUE SOLID E	0583

MODEL LABEL

(1) A label called “Model Label” is affixed in the location as indicated in (3) below. When using this parts catalogue, please be sure to cross-reference the “model code – production code No.” in the catalogue with the “model code – production code No.” indicated on the Model Label affixed onto the product concerned.

(2) “Model Label” Indication

<table border="0"> <tr> <td style="text-align: center;">a</td> <td style="text-align: center;">b</td> </tr> <tr> <td style="text-align: center;">○ xxxx – xxx</td> <td></td> </tr> <tr> <td style="text-align: center;">● x c</td> <td></td> </tr> </table>	a	b	○ xxxx – xxx		● x c		a: Model Type Code b: Production Code No. c: Colouring Type	<table border="0"> <tr> <td style="text-align: center;">○ 4TW1-010</td> </tr> <tr> <td style="text-align: center;">● A</td> </tr> </table>	○ 4TW1-010	● A
a	b									
○ xxxx – xxx										
● x c										
○ 4TW1-010										
● A										

(3) Model Label Affixing Location

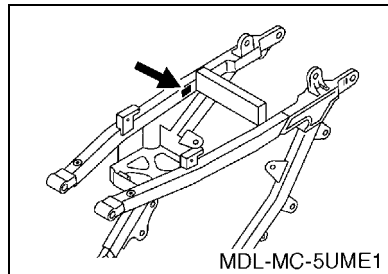

(4) Colouring Information

Model Code	Colouring Type Code	Colour Code	Colour Name	Abbreviation
5TJM	A	0583	DEEP PURPLISH BLUE SOLID E	DPBSE

(5) Model Code – Production Code Number of Model Listed in This Parts Catalogue

Model Code	Production Code No.	Country (destination)	Model Code	Production Code No.	Country (destination)
5TJM	010	AUSTRALIA			
		NEW ZEALAND			
	020	SOUTH AFRICA			

CONTENTS

ENGINE

CYLINDER	B2
CRANKSHAFT & PISTON	B3
VALVE	B4
CAMSHAFT & CHAIN	B6
WATER PUMP	B7
RADIATOR & HOSE	B8
OIL PUMP	B10
OIL CLEANER	B11
INTAKE	B12
CARBURETOR	B14
AIR INDUCTION SYSTEM	C4
EXHAUST	C5
CRANKCASE	C6
CRANKCASE COVER 1	C8
STARTER	C10
STARTER CLUTCH	C11
CLUTCH	C12
TRANSMISSION	C13
SHIFT CAM & FORK	C15
SHIFT SHAFT	D2

CHASSIS

FRAME	D3
FENDER	D5
SIDE COVER	D6
REAR ARM	D7
REAR SUSPENSION	D9
STEERING	D10
FRONT FORK	D11
FUEL TANK	D13
SEAT	D15
FRONT WHEEL	E2
FRONT BRAKE CALIPER	E3
REAR WHEEL	E4
REAR BRAKE CALIPER	E6
STEERING HANDLE & CABLE	E7
FRONT MASTER CYLINDER	E8
STAND & FOOTREST	E9
REAR MASTER CYLINDER	E10
GENERATOR	E11
STARTING MOTOR	E12

METER	E13
HEADLIGHT	E14
TAILLIGHT	E15
HANDLE SWITCH & LEVER	F2
ELECTRICAL 1	F3
ALTERNATE FOR CHASSIS	F5

INDEX

NUMERICAL INDEX	M1
-----------------------	----

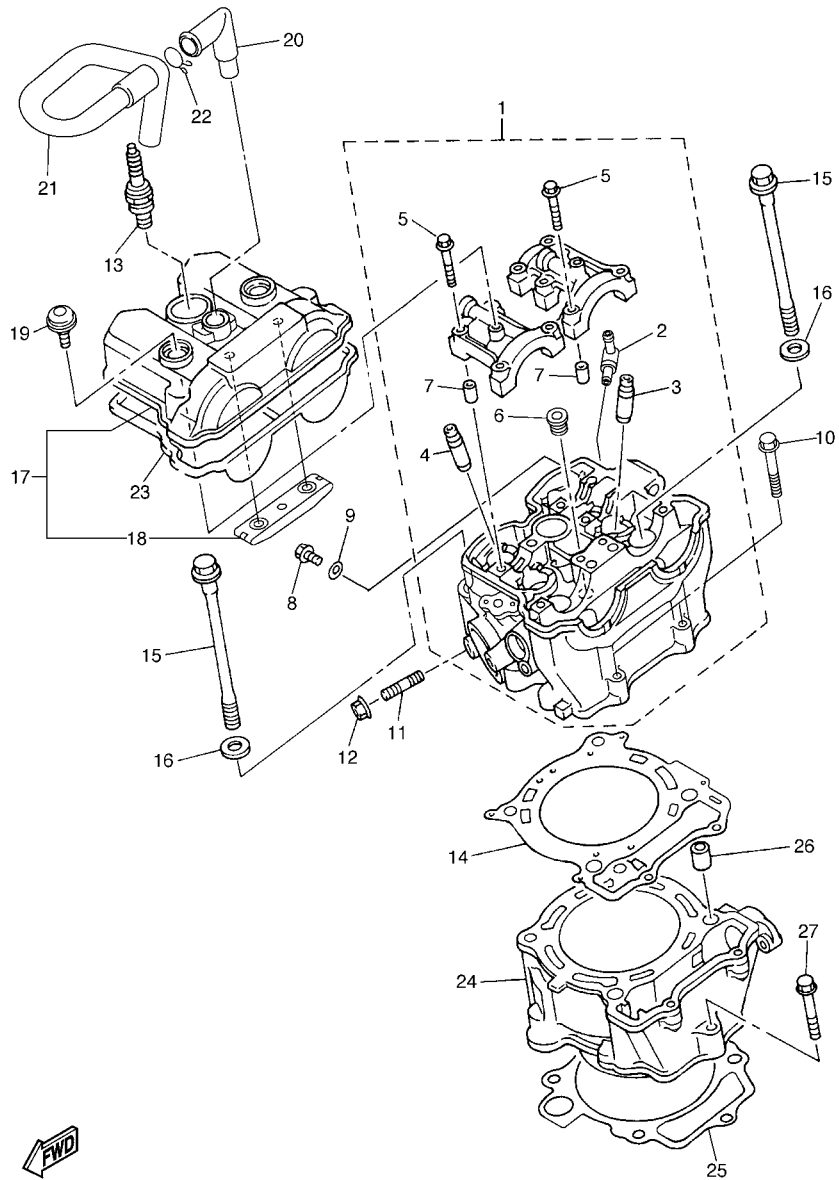

5TJE100-F010

FIG. 1 CYLINDER

REF. NO.	PART NO.	DESCRIPTION	STJM				REMARKS
1	5TJ-11101-10	CYLINDER HEAD ASSY	1				
2	353-13115-01	.CONNECTOR, SUCTION PIPE	1				
3	5TA-11133-10	.GUIDE, VALVE 1	3				
4	5TA-11134-10	.GUIDE, VALVE 2	2				
5	90105-06027	.BOLT, FLANGE	10				
6	90340-12007	.PLUG, STRAIGHT SCREW	1				
7	91808-16023	.PIN, DOWEL	4				
8	95022-06010	BOLT, FLANGE	1				
9	90430-06014	GASKET	1				
10	95022-06035	BOLT, FLANGE	2				
11	90116-08022	BOLT, STUD	1				
12	95702-08500	NUT, WITH WASHER	1				
13	94701-00411	PLUG, SPARK (NGK R CR8E)	1				
14	2S2-11181-00	GASKET, CYLINDER HEAD 1	1				
15	90105-10163	BOLT, FLANGE	4				
16	90201-10025	WASHER, PLATE	4				
17	2S2-11190-10	COVER, CYLINDER HEAD 1	1				
18	5BE-12241-00	.GUIDE, STOPPER 2	1				
19	5UM-1119E-00	BOLT, COVER HEAD	2				
20	3P6-11167-00	PIPE, BREATHER 2	1				
21	5TJ-11166-10	PIPE, BREATHER 1	1				
22	90467-160A4	CLIP	1				
23	2S2-11193-00	GASKET, HEAD COVER 1	1				
24	2S2-11311-10	CYLINDER 1	1				
25	2S2-11351-00	GASKET, CYLINDER	1				
26	93612-16254	PIN, DOWEL	2				
27	95022-06035	BOLT, FLANGE	1				

FIG. 2 CRANKSHAFT & PISTON

REF. NO.	PART NO.	DESCRIPTION	STJM				REMARKS
1	5TJ-11400-20	CRANKSHAFT ASSY	1				
2	5TJ-11412-20	.CRANK 1	1				
3	2S2-11422-00	.CRANK 2	1				
4	5TG-11681-00	.PIN, CRANK 1	1				
5	93310-63417	.BEARING	1				
6	2S2-11651-00	.ROD, CONNECTING	1				
7	93306-30633	BEARING	2				
8	2S2-11536-00	GEAR, DRIVE	1				
9	2S2-11455-00	SHAFT 1	1				
10	93304-20310	BEARING	2				
11	2S2-11531-00	GEAR, BALANCE WEIGHT	1				
12	90170-14171	NUT	1				
13	90215-14287	WASHER, LOCK	1				
14	2S2-11454-00	WEIGHT 1	1				
15	90149-06083	SCREW	3				
16	2S2-11464-00	WEIGHT 2	1				
17	90282-05034	KEY, STRAIGHT	1				
18	90170-10405	NUT	1				
19	90215-10009	WASHER, LOCK	1				
20	90280-03006	KEY, WOODRUFF	1				
21	2S2-11631-20	PISTON (STD)	1				
22	5JG-11603-00	PISTON RING SET (STD)	1				
23	5TA-11633-00	PIN, PISTON	1				
24	93420-18082	CIRCLIP	2				

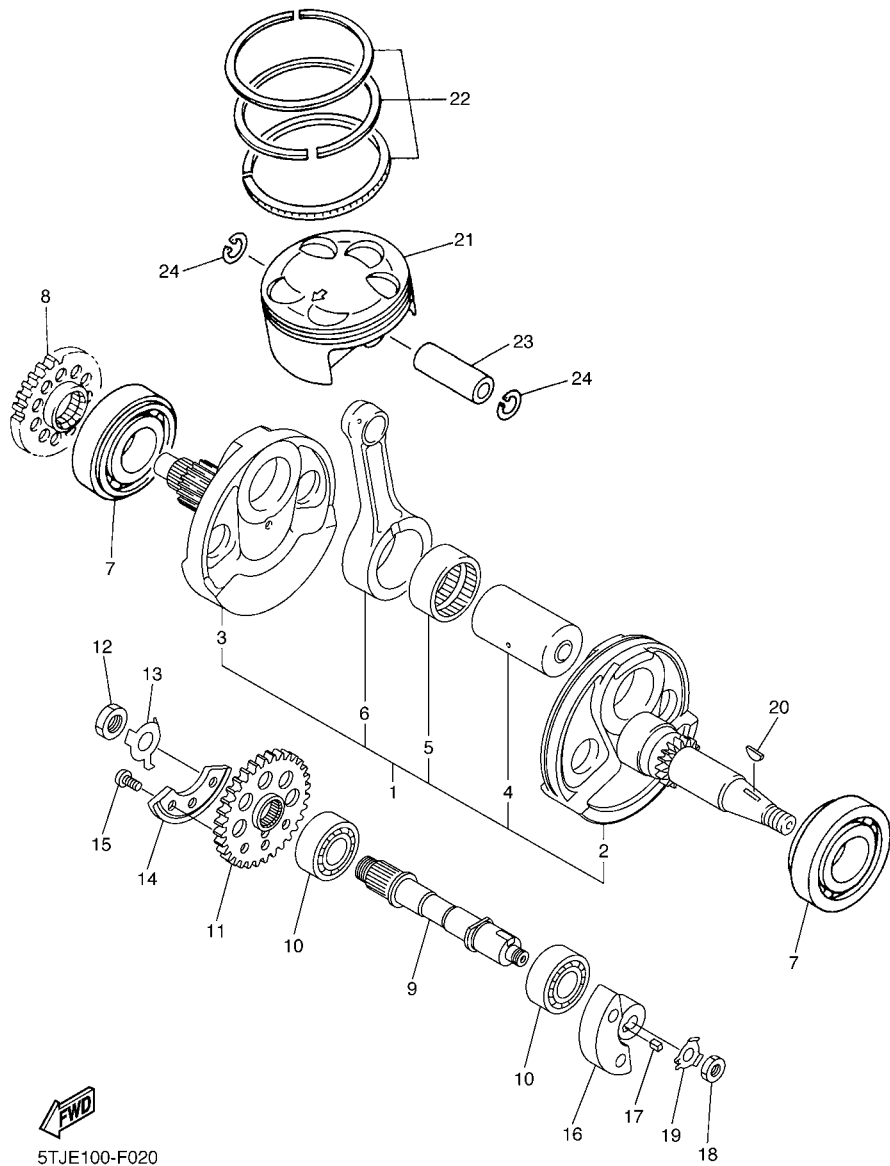

5TJE100-F020

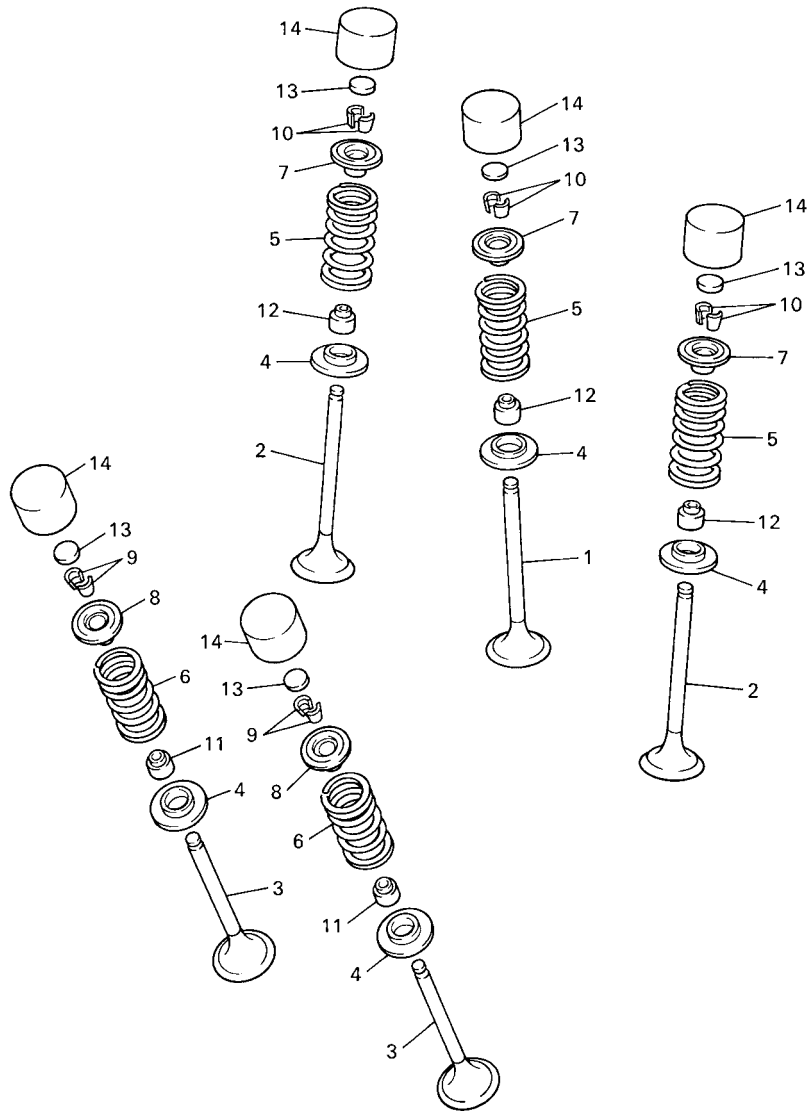

5BE100-8030

FIG. 3 VALVE

REF. NO.	PART NO.	DESCRIPTION	STJM				REMARKS
1	5TA-12111-00	VALVE, INTAKE	1				
2	5TA-12112-00	VALVE, INTAKE 2	2				
3	5TA-12121-00	VALVE, EXHAUST	2				
4	3GM-12126-00	SEAT, VALVE SPRING 2	5				
5	5TJ-12113-00	SPRING, VALVE INNER	3				
6	5TJ-12114-00	SPRING, VALVE OUTER	2				
7	5BE-12117-00	RETAINER, VALVE SPRING	3				
8	4GY-12117-00	RETAINER, VALVE SPRING	2				
9	1AA-12118-00	COTTER, VALVE	4				
10	1WG-12118-00	COTTER, VALVE	6				
11	33M-12119-00	SEAL, VALVE STEM	2				
12	4SV-12119-00	SEAL, VALVE STEM	3				
13	3LD-12168-00	PAD, ADJUSTING (1.20)	5				UR
	3LD-12168-20	PAD, ADJUSTING (1.25)	5				UR
	3LD-12168-40	PAD, ADJUSTING (1.30)	5				UR
	3LD-12168-60	PAD, ADJUSTING (1.35)	5				UR
	3LD-12168-80	PAD, ADJUSTING (1.40)	5				UR
	3LD-12168-A0	PAD, ADJUSTING (1.45)	5				UR
	3LD-12168-F0	PAD, ADJUSTING (1.50)	5				UR
	3LD-12168-H1	PAD, ADJUSTING (1.55)	5				UR
	3LD-12168-K1	PAD, ADJUSTING (1.60)	5				UR
	3LD-12168-M1	PAD, ADJUSTING (1.65)	5				UR
	3LD-12168-R1	PAD, ADJUSTING (1.70)	5				UR
	3LD-12168-U1	PAD, ADJUSTING (1.75)	5				UR
	3LD-12168-W1	PAD, ADJUSTING (1.80)	5				UR
	3LD-12168-Y1	PAD, ADJUSTING (1.85)	5				UR
	3LD-12169-11	PAD, ADJUSTING (1.90)	5				UR

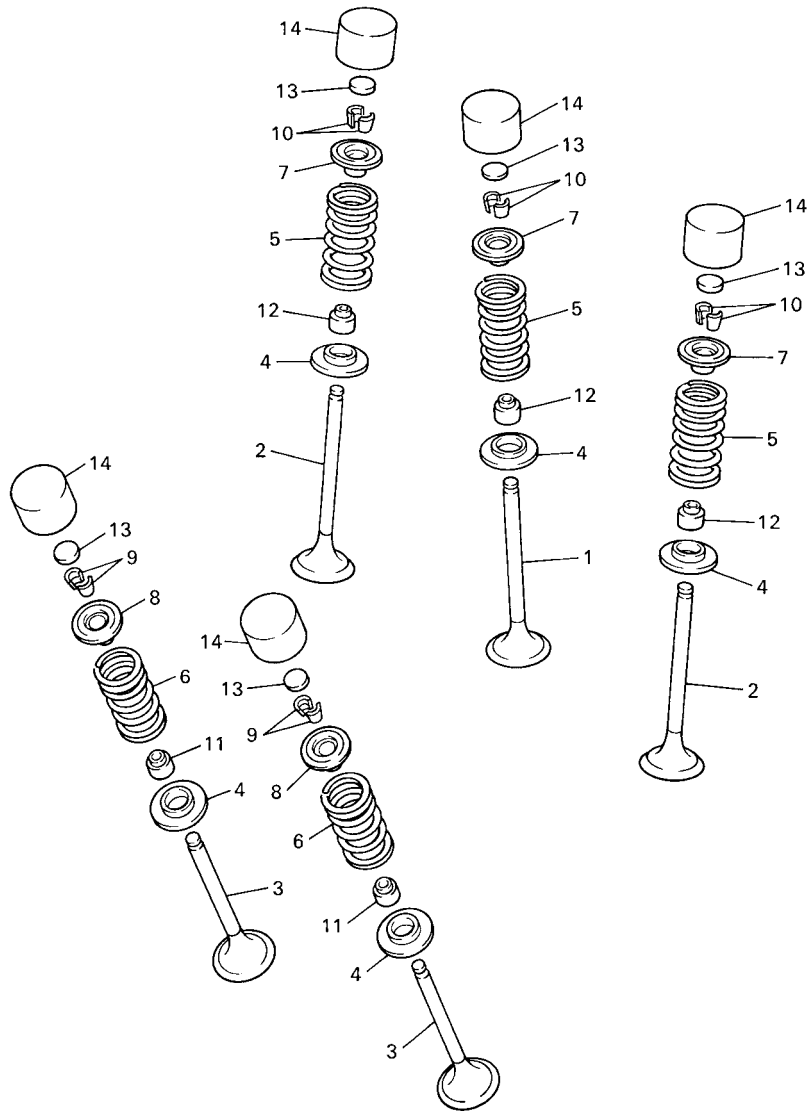

5BE100-8030

FIG. 3 VALVE

REF. NO.	PART NO.	DESCRIPTION	STJM				REMARKS
13	3LD-12169-31	PAD, ADJUSTING (1.95)	5				UR
	3LD-12169-50	PAD, ADJUSTING (2.00)	5				UR
	3LD-12169-70	PAD, ADJUSTING (2.05)	5				UR
	3LD-12169-90	PAD, ADJUSTING (2.10)	5				UR
	3LD-12169-E0	PAD, ADJUSTING (2.15)	5				UR
	3LD-12169-G0	PAD, ADJUSTING (2.20)	5				UR
	3LD-12169-J0	PAD, ADJUSTING (2.25)	5				UR
	3LD-12169-L0	PAD, ADJUSTING (2.30)	5				UR
	3LD-12169-N0	PAD, ADJUSTING (2.35)	5				UR
	3LD-12169-T0	PAD, ADJUSTING (2.40)	5				UR
14	3FV-12153-10	LIFTER, VALVE	5				YELLOW

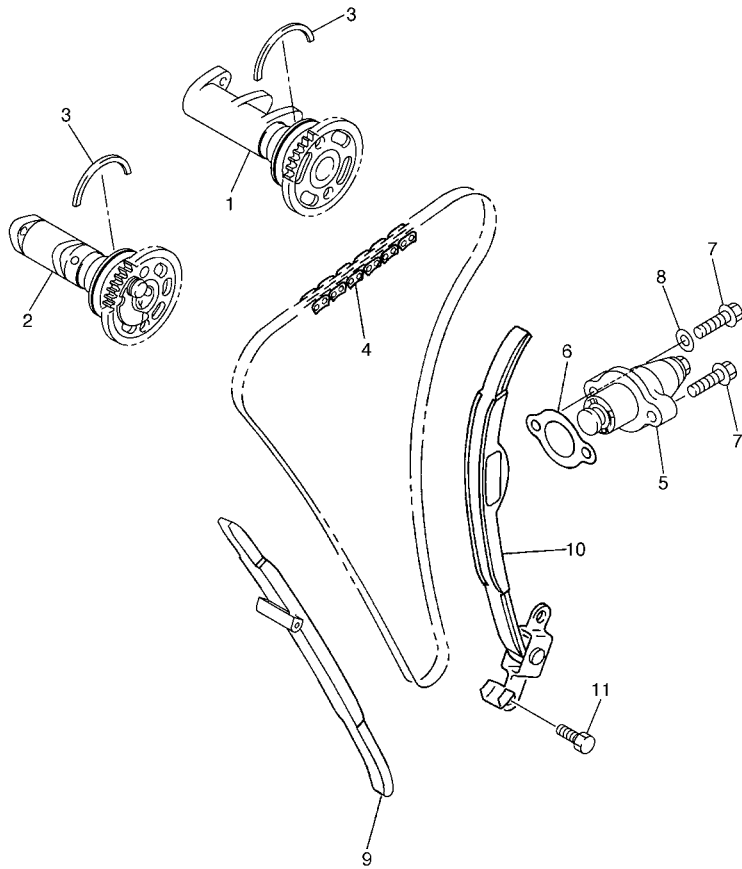
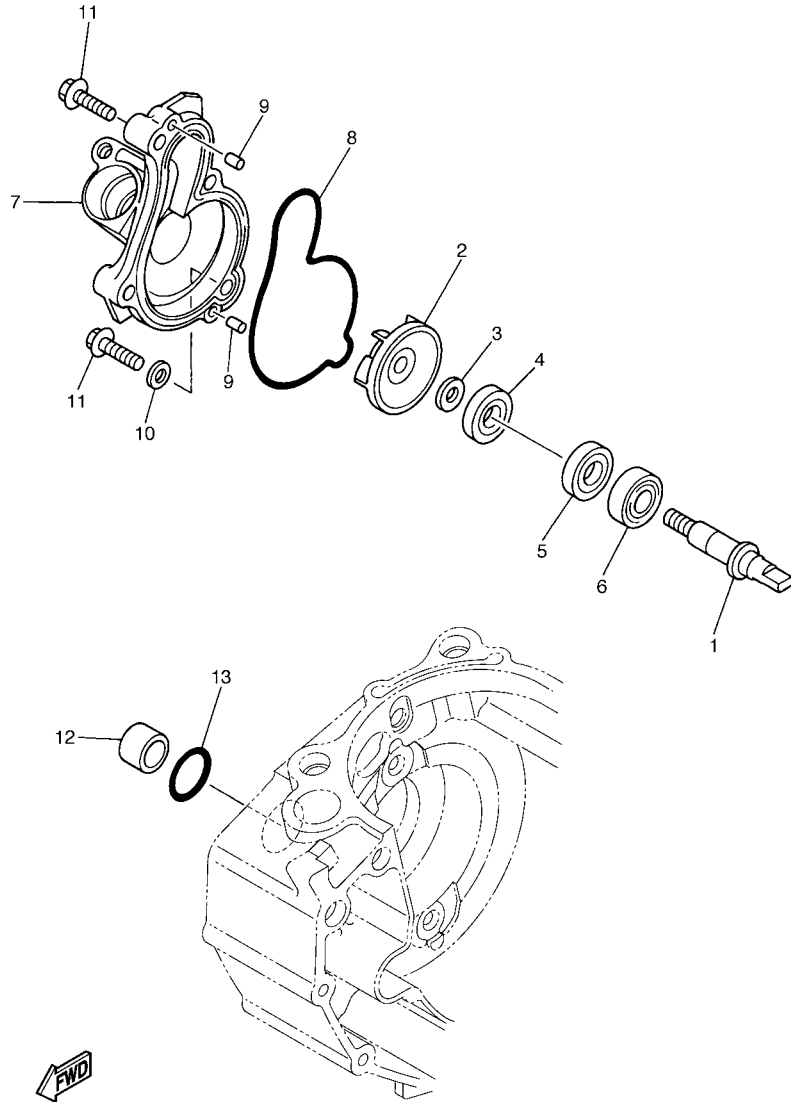

FIG. 4 CAMSHAFT & CHAIN

REF. NO.	PART NO.	DESCRIPTION	5TJM				REMARKS
1	5TJ-12170-00	CAMSHAFT ASSY 1	1				
2	5TJ-12180-30	CAMSHAFT ASSY 2	1				
3	93440-41178	CIRCLIP	2				
4	94591-57118	CHAIN (98XRH2010-118M)	1				
5	5TA-12210-10	TENSIONER ASSY, CAM CHAIN	1				
6	4FM-12213-00	GASKET, TENSIONER CASE	1				
7	95022-06025	BOLT, FLANGE	2				
8	90430-06014	GASKET	1				
9	2S2-12251-00	DAMPER, CHAIN 1	1				
10	5TA-12252-00	DAMPER, CHAIN 2	1				
11	5TJ-12299-00	BOLT, STOPPER	2				



5TJE100-F040



2S21100-E050

FIG. 5 WATER PUMP

REF. NO.	PART NO.	DESCRIPTION	STJM				REMARKS
1	5GR-12458-00	SHAFT, IMPELLER	1				
2	5DJ-12451-00	IMPELLER, WATER PUMP	1				
3	90201-08512	WASHER, PLATE	1				
4	93109-11073	OIL SEAL	1				
5	93102-12106	OIL SEAL (SD 12-22-5 HS)	1				
6	93306-00105	BEARING	1				
7	5BE-12422-20	COVER, HOUSING	1				
8	5BE-12439-00	O-RING	1				
9	93604-10011	PIN, DOWEL	2				
10	90430-06014	GASKET	1				
11	95022-06030	BOLT, FLANGE	4				
12	5BE-12564-00	PIPE, WATER	1				
13	93210-19758	O-RING	1				

FIG. 6 RADIATOR & HOSE

REF. NO.	PART NO.	DESCRIPTION	STJM				REMARKS
1	5TJ-1240A-E0	RADIATOR ASSY	1				
2	2S2-12464-70	.STAY, RADIATOR	1				
3	92012-06010	.BOLT, BUTTON HEAD	3				
4	90183-060A6	.NUT, SPRING	1				
5	2S2-12461-70	RADIATOR ASSY	1				
6	2S2-12464-70	.STAY, RADIATOR	1				
7	92012-06010	.BOLT, BUTTON HEAD	3				
8	90183-060A6	.NUT, SPRING	1				
9	22W-12462-00	CAP, RADIATOR	1				
10	91A20-05140	TUBE, FLEXIBLE VINYL	1				
11	90467-090A2	CLIP	1				
12	2S2-12481-00	PIPE 1	1				
13	91312-06012	BOLT	1				
14	93210-16500	O-RING	1				
15	2S2-12576-00	HOSE 1	1				
16	1C3-12482-00	PIPE 2	1				
17	2S2-12578-00	HOSE 3	1				
18	5TJ-12579-E0	HOSE 4	1				
19	2S2-12482-00	PIPE 2	1				
20	95022-06012	BOLT, FLANGE	1				
21	93210-16500	O-RING	1				
22	90450-28001	HOSE CLAMP ASSY	3				
23	90450-25001	HOSE CLAMP ASSY	3				
24	90450-22001	HOSE CLAMP ASSY	2				
25	90480-15528	GROMMET	4				
26	90387-06065	COLLAR	4				
27	90105-06111	BOLT, FLANGE	4				

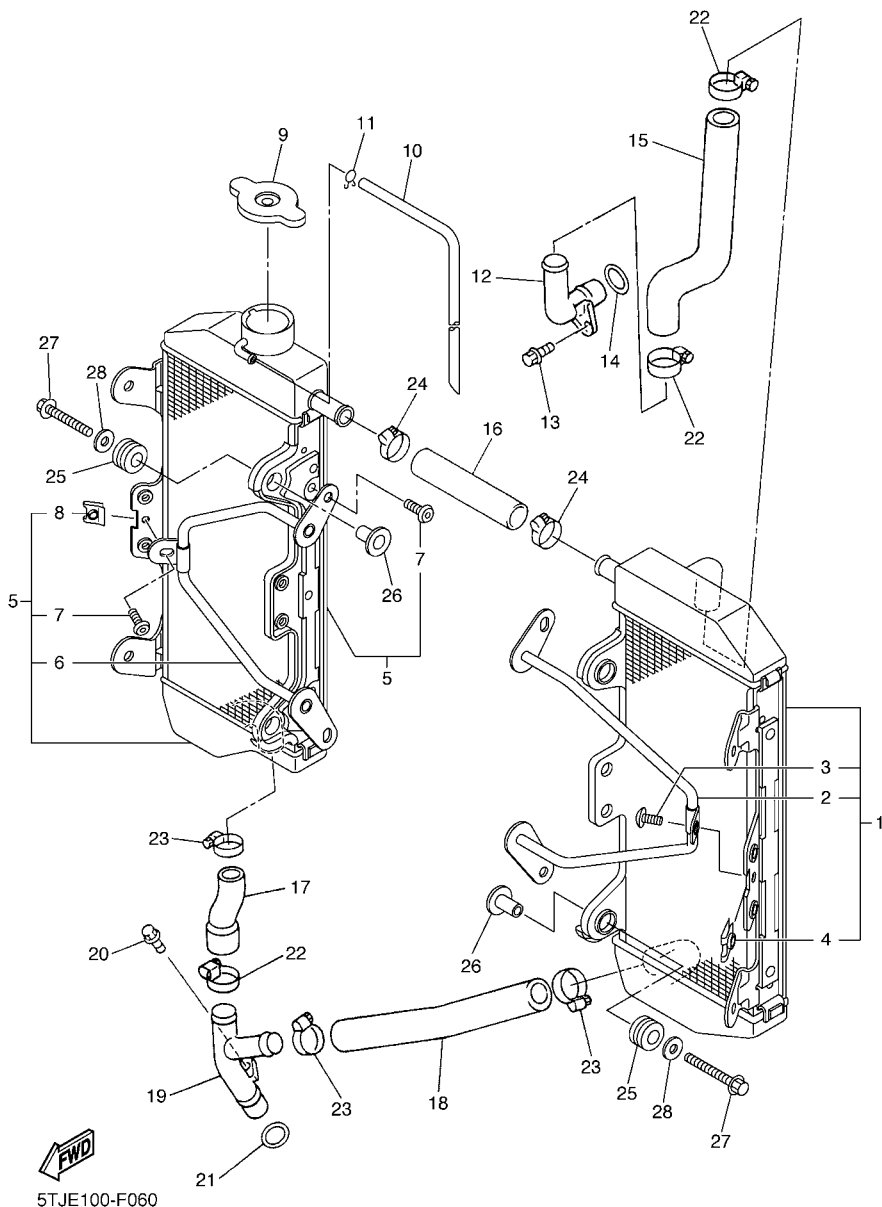

5TJE100-F060

FIG. 6 RADIATOR & HOSE

REF. NO.	PART NO.	DESCRIPTION	5TJM				REMARKS
----------	----------	-------------	------	--	--	--	---------

28	90201-06571	WASHER, PLATE	4				

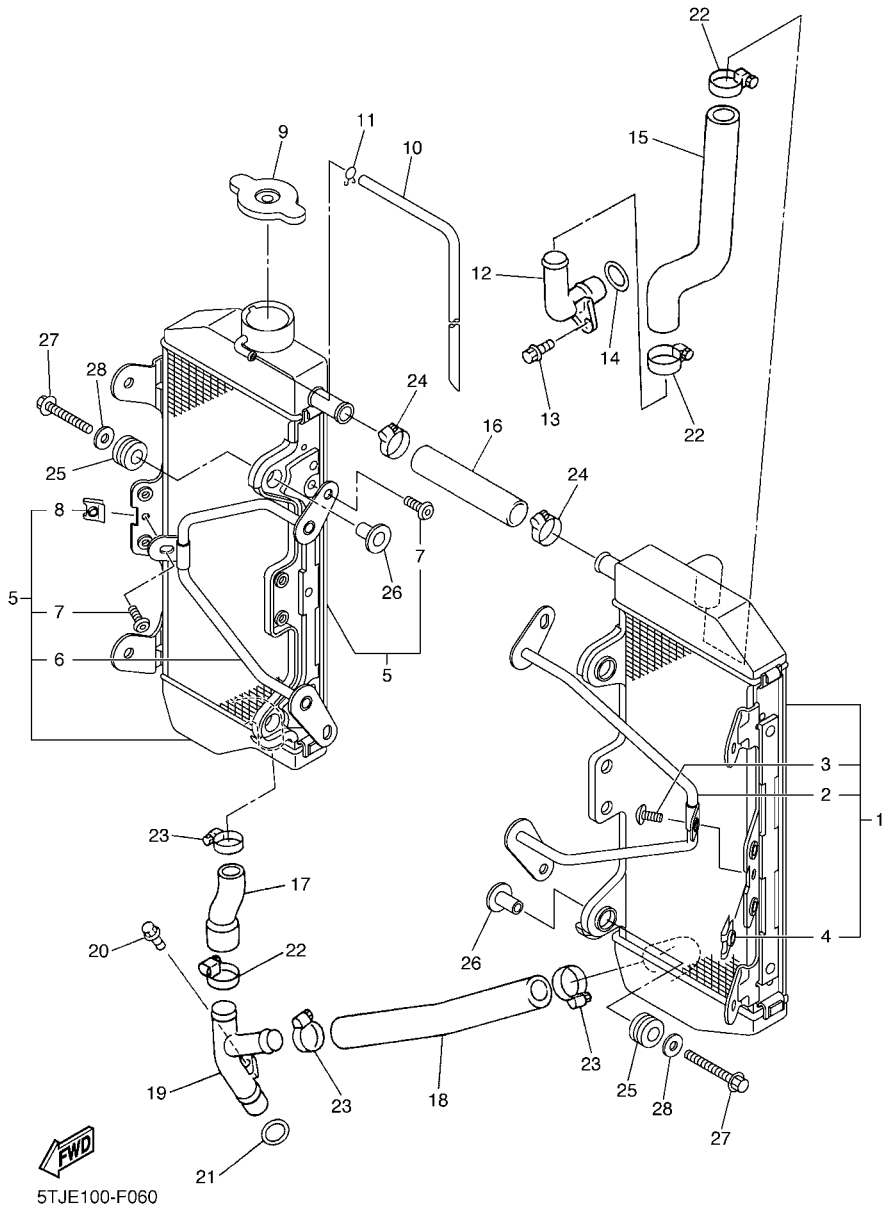
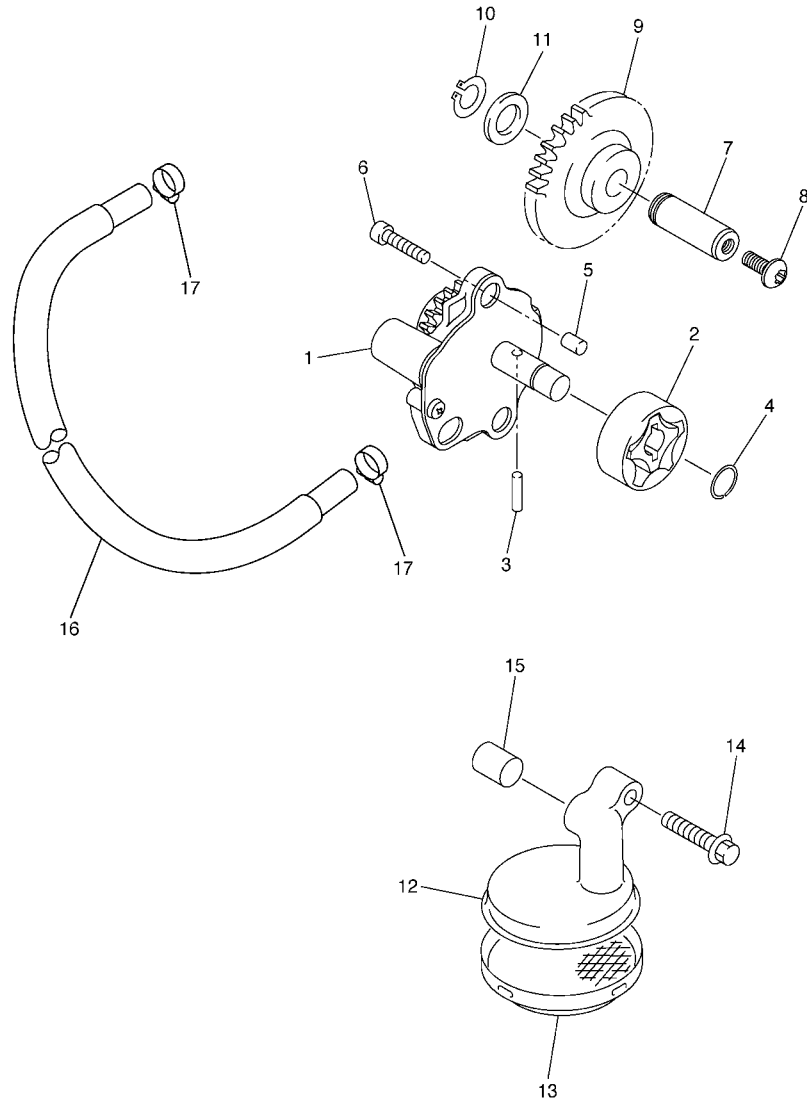

FIG. 7 OIL PUMP



REF. NO.	PART NO.	DESCRIPTION	STJM				REMARKS
1	2S2-13300-10	OIL PUMP ASSY	1				
2	5TA-13320-00	ROTOR ASSY 2	1				
3	93603-16219	PIN, DOWEL	1				
4	93440-10153	CIRCLIP	1				
5	99530-08012	PIN, DOWEL	2				
6	91312-06030	BOLT	2				
7	2S2-13342-00	SHAFT, IDLE GEAR	1				
8	90149-06068	SCREW	1				
9	2S2-13341-00	GEAR, OIL PUMP IDLE	1				
10	99009-12400	CIRCLIP	1				
11	90201-12166	WASHER, PLATE	1				
12	2S2-13412-00	HOUSING, STRAINER	1				
13	5BE-13411-00	STRAINER, OIL	1				
14	95022-06030	BOLT, FLANGE	1				
15	99530-10114	PIN, DOWEL	1				
16	90445-14009	HOSE	1				
17	90450-17001	HOSE CLAMP ASSY	2				



2S21100-E070

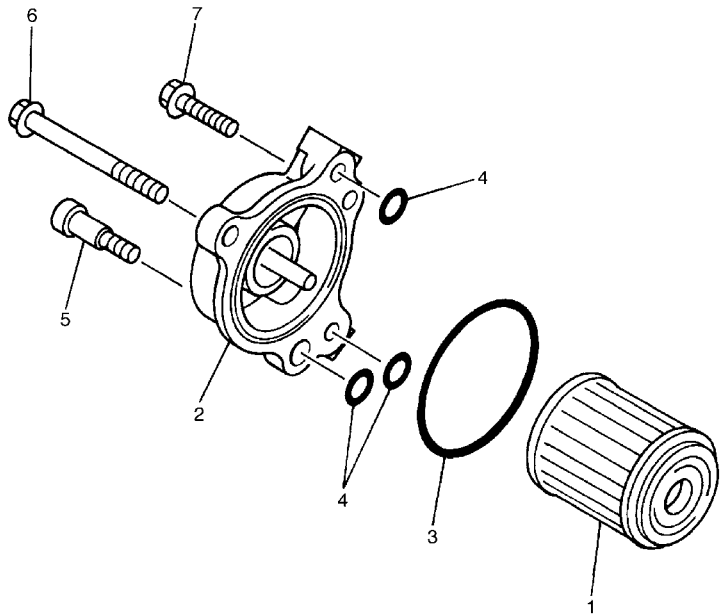
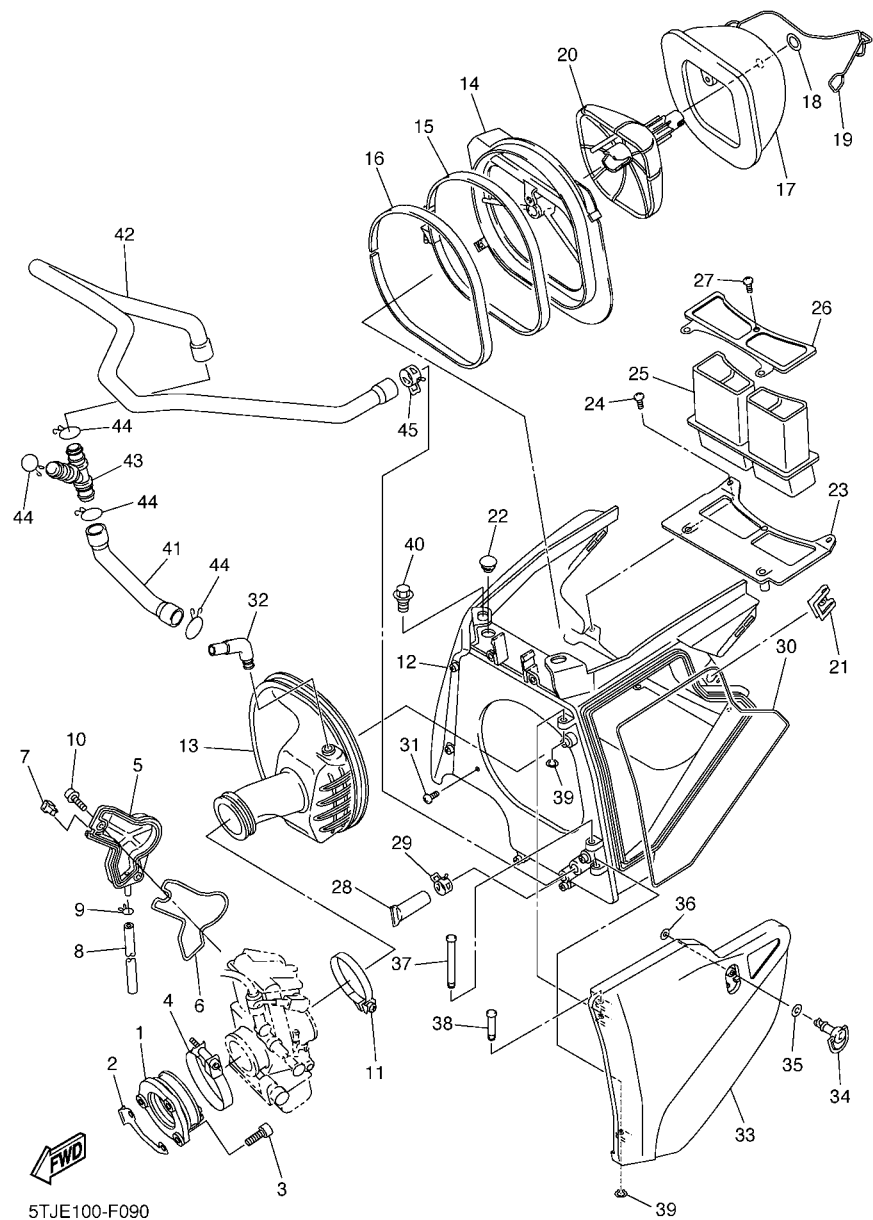

FIG. 8 OIL CLEANER

REF. NO.	PART NO.	DESCRIPTION	ST./M					REMARKS
1	5TA-13440-00	ELEMENT ASSY, OIL CLEANER	1					
2	5BE-13447-20	COVER, OIL ELEMENT	1					
3	93210-47675	O-RING	1					
4	93210-07135	O-RING	3					
5	90110-06228	BOLT, HEXAGON SOCKET HEAD	1					
6	91312-06065	BOLT	1					
7	91312-06020	BOLT	1					



5TJE100-F090

FIG. 9 INTAKE

REF. NO.	PART NO.	DESCRIPTION	STJM				REMARKS
1	2S2-13597-00	JOINT, CARBURETOR 3	1				
2	5TJ-14291-00	BRACKET 1	1				
3	91312-06020	BOLT	3				
4	90450-57010	HOSE CLAMP ASSY	1				
5	5TA-14293-00	COVER 1	1				
6	5TA-14227-00	GASKET	1				
7	5TA-14239-00	SEAL	1				
8	5TA-14987-00	HOSE	1				
9	3TJ-14137-40	CLIP	1				
10	90110-05038	BOLT, HEXAGON SOCKET HEAD	2				
11	90450-61002	HOSE CLAMP ASSY	1				
12	5UM-14401-E0	AIR CLEANER CASE ASSY	1				
13	5TJ-14453-E0	JOINT, AIR CLEANER 1	1				
14	5TJ-14459-01	HOLDER, GUIDE	1				
15	5NY-14455-20	BAND	1				
16	5NY-14442-00	SPACER	1				
17	5UM-14451-E0	ELEMENT, AIR CLEANER	1				
18	5TJ-14475-00	WASHER	1				
19	5UM-1441G-E0	BINDER 1	1				
20	5TJ-14458-00	GUIDE	1				
21	4XV-2177L-01	PLATE, SPRING	1				
22	90338-07043	PLUG	1				
23	5UM-14437-E0	DUCT	1				
24	97702-50516	SCREW, TAPPING	2				
25	5UM-1443A-E0	DUCT	1				
26	5UM-14417-E0	COVER 1	1				
27	97702-50516	SCREW, TAPPING	3				

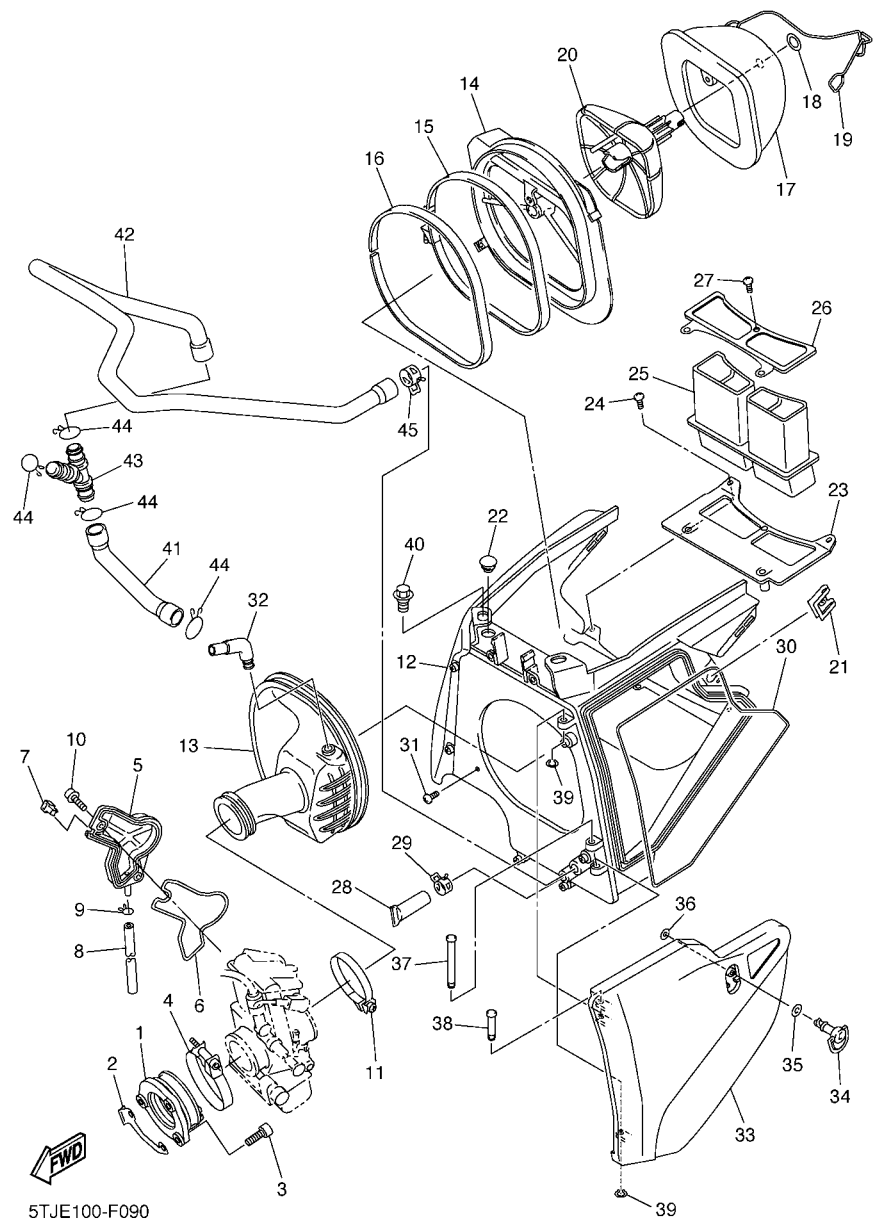
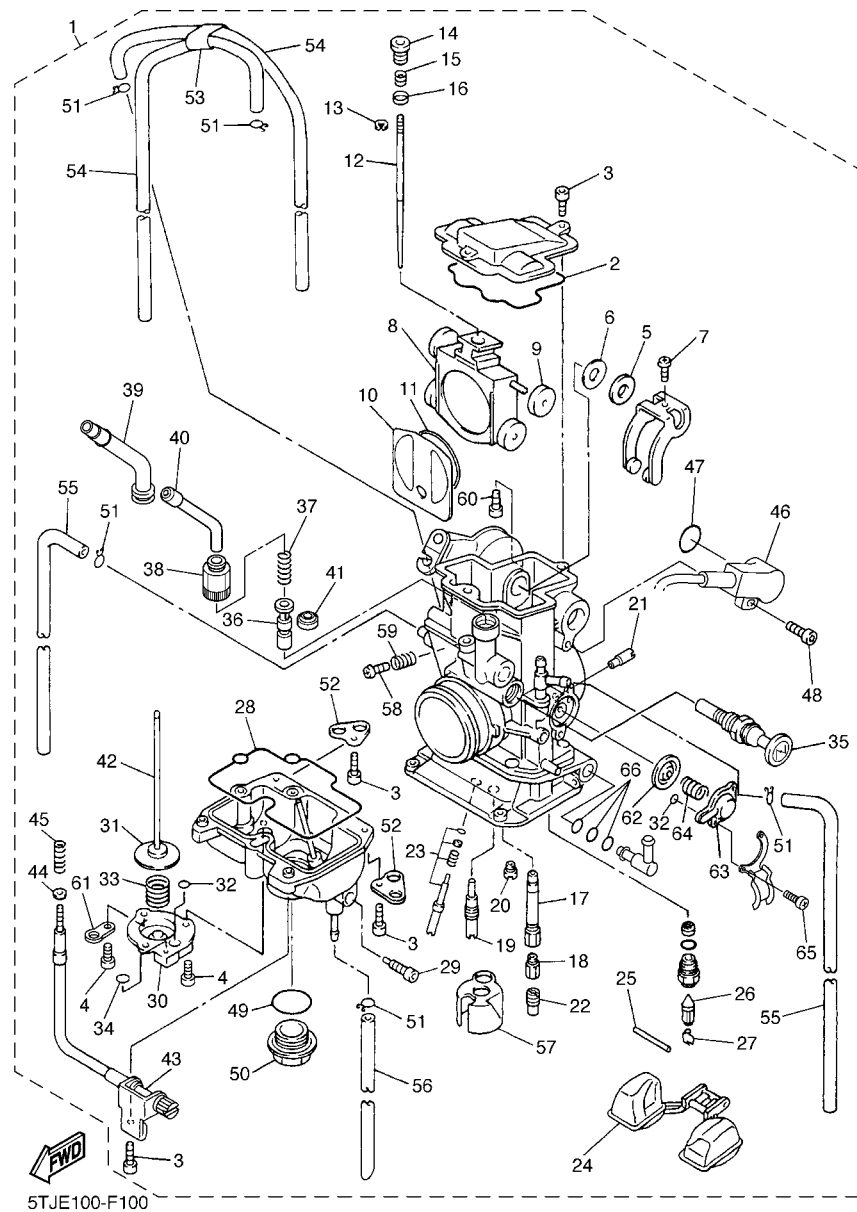

FIG. 9 INTAKE

REF. NO.	PART NO.	DESCRIPTION	5TJM				REMARKS
28	5BF-1443E-00	PIPE, DRAIN	1				
29	90467-17089	CLIP	1				
30	5UM-14462-E0	SEAL	1				
31	97702-50516	SCREW, TAPPING	1				
32	5TJ-14419-00	PIPE	1				
33	5UM-1441A-E0	COVER, CLEANER CASE 1	1				
34	3FV-28386-00	HEAD	1				
35	2TK-21757-00	WASHER, SPECIAL 1	1				
36	5TJ-21757-00	WASHER, SPECIAL 1	1				
37	90249-05005	PIN	1				
38	90249-05004	PIN	1				
39	99002-04600	CIRCLIP	2				
40	90109-06245	BOLT	2				
41	5TJ-11167-10	PIPE, BREATHER 2	1				
42	5TJ-11126-00	PIPE, BREATHER 3	1				
43	90413-14001	WAY 3	1				
44	90467-160A4	CLIP	4				
45	90467-17089	CLIP	1				



5TJE100-F100

FIG. 10 CARBURETOR

REF. NO.	PART NO.	DESCRIPTION	STJM			REMARKS
1	5TJ-14101-E0	CARBURETOR ASSY 1	1			
2	5JG-14959-00	.GASKET	1			
3	91316-04012	.BOLT	6			
4	688-14592-00	.SCREW	3			
5	90202-08045	.WASHER, PLATE	1			
6	5JG-14951-00	.WASHER	1			
7	5JG-14522-00	.SCREW, ADJUST	1			
8	2S2-14388-00	.VALVE, VACUUM CONTROL	1			
9	3TJ-14267-40	.ROLLER	1			
10	5JG-14546-01	.VALVE, NEEDLE	1			
11	4FN-14997-00	.SEAL	1			
12	5TJ-14916-NT	.NEEDLE (NFNT)	1			STD
	5TJ-14916-9M	.NEEDLE (GDDUM)	1			AP
	5TJ-14916-9N	.NEEDLE (GDDUN)	1			AP
	5TJ-14916-9P	.NEEDLE (GDDUP)	1			AP
	5TJ-14916-91	.NEEDLE (GDDUQ)	1			AP
	5TJ-14916-9R	.NEEDLE (GDDUR)	1			AP
	5TJ-14916-9S	.NEEDLE (GDDUS)	1			AP
	5TJ-14916-9T	.NEEDLE (GDDUT)	1			AP
	5TJ-14916-AM	.NEEDLE (GDDSM)	1			AP
	5TJ-14916-AN	.NEEDLE (GDDSN)	1			AP
	5TJ-14916-AP	.NEEDLE (GDDSP)	1			AP
	5TJ-14916-A1	.NEEDLE (GDDSQ)	1			AP
	5TJ-14916-AR	.NEEDLE (GDDSR)	1			AP
	5TJ-14916-AS	.NEEDLE (GDDSS)	1			AP
	5TJ-14916-AT	.NEEDLE (GDDST)	1			AP
13	3TJ-14159-40	.CLIP	1			

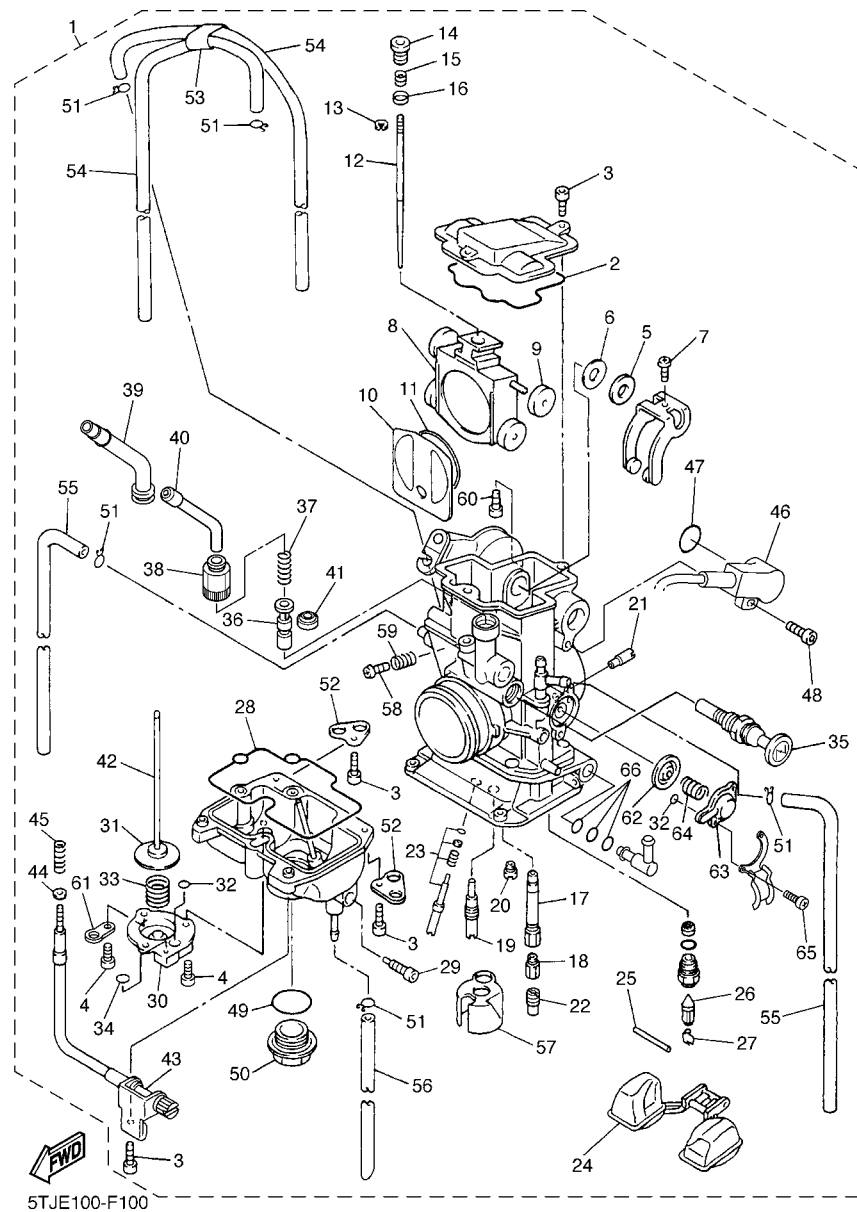

5TJE100-F100

FIG. 10 CARBURETOR

REF. NO.	PART NO.	DESCRIPTION	STJM				REMARKS
14	5JG-14521-00	.SCREW, ADJUST	1				
15	5JG-14275-00	.SPRING	1				
16	5JG-14264-00	.COLLAR	1				
17	5TJ-14947-00	.JET, NEEDLE	1				
18	4MX-14943-90	.JET, MAIN (#162)	1				STD
	4MX-14943-40	.JET, MAIN (#165)	1				AP
	4MX-14943-91	.JET, MAIN (#168)	1				AP
	4MX-14943-41	.JET, MAIN (#170)	1				AP
	4MX-14943-92	.JET, MAIN (#172)	1				AP
	4MX-14943-42	.JET, MAIN (#175)	1				AP
	4MX-14943-93	.JET, MAIN (#178)	1				AP
	4MX-14943-43	.JET, MAIN (#180)	1				AP
	4MX-14943-94	.JET, MAIN (#182)	1				AP
	4MX-14943-44	.JET, MAIN (#185)	1				AP
19	4MX-14948-05	.JET, SLOW (#45)	1				STD
	4MX-14948-06	.JET, SLOW (#48)	1				AP
	4MX-14948-07	.JET, SLOW (#50)	1				AP
	4MX-14948-08	.JET, SLOW (#52)	1				AP
	4MX-14948-09	.JET, SLOW (#55)	1				AP
20	3TJ-1494F-13	.JET (#65)	1				STD
	3TJ-1494F-11	.JET (#60)	1				AP
	3TJ-1494F-12	.JET (#62)	1				AP
	3TJ-1494F-14	.JET (#68)	1				AP
	3TJ-1494F-15	.JET (#70)	1				AP
21	5TA-14943-15	.JET, MAIN (#70)	1				
22	4JT-1494F-11	.JET (#60)	1				STD
	4JT-1494F-01	.JET (#35)	1				AP

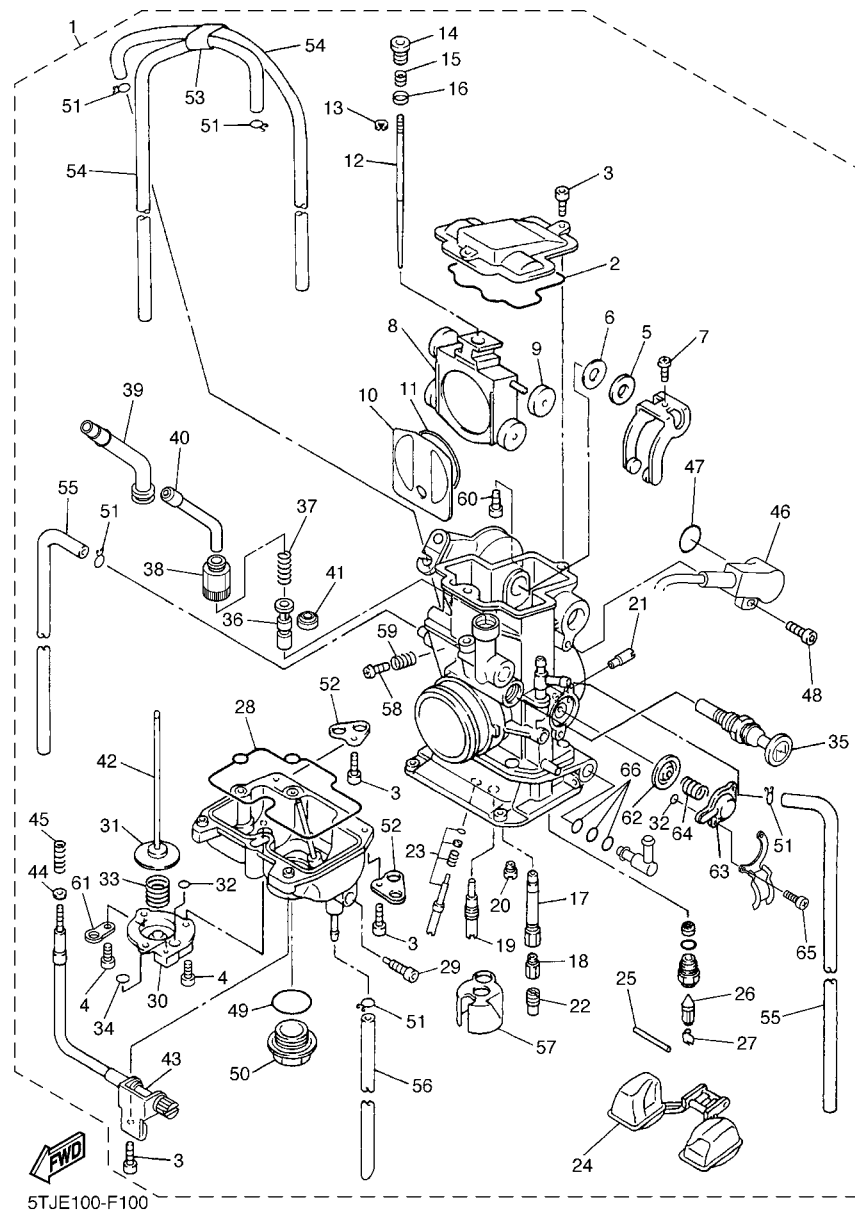

5TJE100-F100

FIG. 10 CARBURETOR

REF. NO.	PART NO.	DESCRIPTION	STJM			REMARKS
22	4JT-1494F-03	.JET (#40)	1			AP
	4JT-1494F-05	.JET (#45)	1			AP
	4JT-1494F-07	.JET (#50)	1			AP
	4JT-1494F-09	.JET (#55)	1			AP
	4JT-1494F-13	.JET (#65)	1			AP
23	5NL-14105-00	.PILOT SCREW SET	1			
24	4SR-14985-00	.FLOAT	1			
25	676-14548-00	.PIN, FLOAT ARM	1			
26	4MX-14392-00	.VALVE, NEEDLE	1			
27	633-14159-00	.CLIP	1			
28	5JG-14984-00	.GASKET, FLOAT CHAMBER	1			
29	3TJ-14191-40	.PLUG, DRAIN	1			
30	3TJ-14293-40	.COVER 1	1			
31	5JG-14940-18	.DIAPHRAGM ASSY	1			STD
	5JG-14940-17	.DIAPHRAGM ASSY	1			AP
	5JG-14940-19	.DIAPHRAGM ASSY	1			AP
32	3TJ-14536-40	.GASKET	2			
33	5GS-14933-40	.SPRING, DIAPHRAGM	1			
34	6H4-14561-00	.O-RING	1			
35	5XC-14171-00	.PLUNGER, STARTER	1			
36	5TA-14371-00	.PLUNGER, STARTER	1			
37	5TA-14335-00	.SPRING, PLUNGER	1			
38	5TA-14991-00	.SCREW	1			
39	2S2-14208-00	.LEVER COMP. 1	1			
40	5TA-14155-00	.GUIDE, CABLE	1			
41	5TA-14997-00	.SEAL	1			
42	5JG-14379-00	.ROD, STARTER	1			

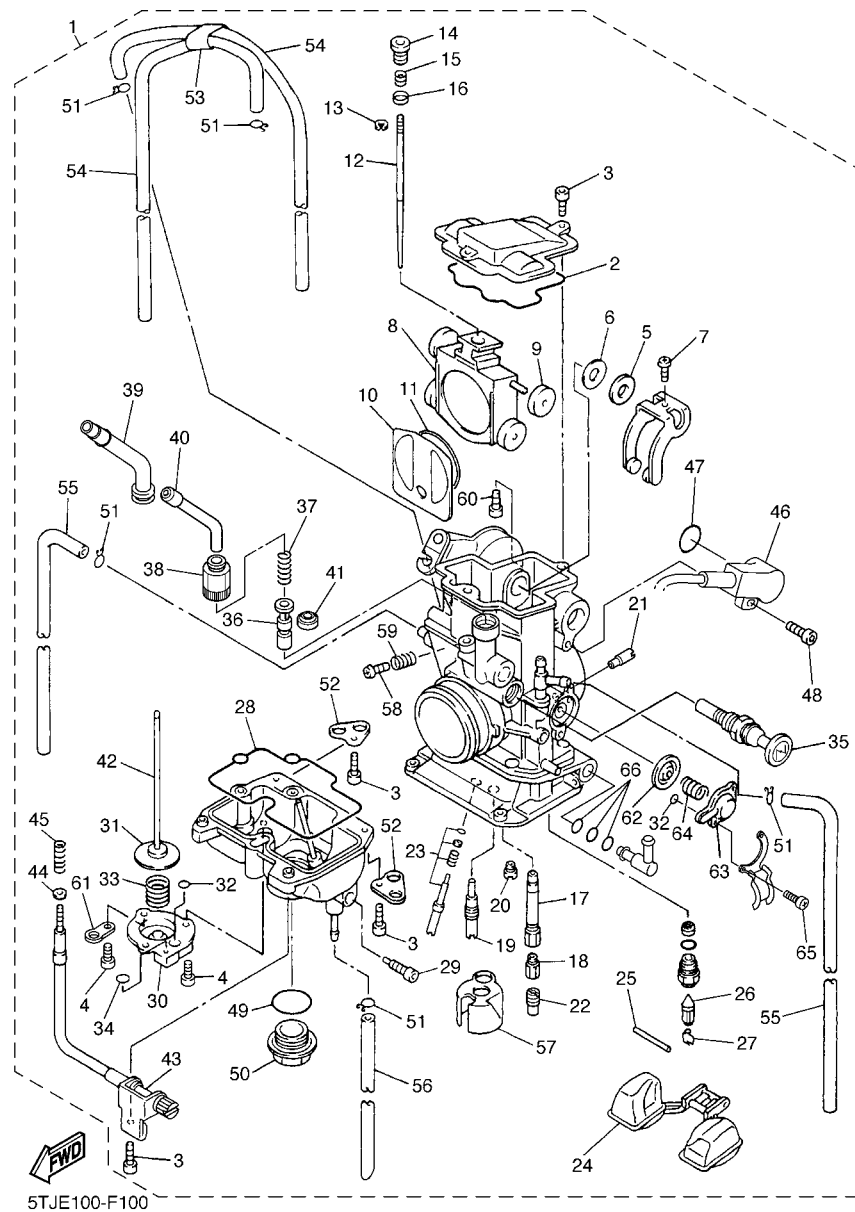

5TJE100-F100

FIG. 10 CARBURETOR

REF. NO.	PART NO.	DESCRIPTION	QTY	REMARKS
43	5XC-14922-00	.SCREW, THROTTLE	1	
44	90201-08410	.WASHER, PLATE	1	
45	5TA-14934-00	.SPRING, THROTTLE STOP	1	
46	5XC-85885-00	.THROTTLE SENSOR ASSY	1	
47	5NX-14562-00	.O-RING	1	
48	5NX-14216-00	.SCREW	1	
49	4MX-14561-00	.O-RING	1	
50	4MX-14115-00	.PLUG, SCREW	1	
51	3TJ-14137-40	.CLIP	5	
52	5BE-14146-00	.PLATE	2	
53	5TA-14261-00	.HOLDER	1	
54	5UL-14196-00	.PIPE	2	
55	5TA-14197-00	.PIPE	2	
56	5TJ-14987-00	.HOSE	1	
57	5JG-14346-00	.PLATE	1	
58	5JG-14565-00	.SCREW	1	
59	5JG-14531-00	.SPRING, ADJUST SCREW	1	
60	5TJ-14591-10	.SCREW	1	
61	5PA-14146-00	.PLATE	1	
62	5GS-14940-00	.DIAPHRAGM ASSY	1	
63	5GS-14958-00	.COVER, DIAPHRAGM	1	
64	5GS-14933-00	.SPRING, DIAPHRAGM	1	
65	97602-04110	.SCREW, PAN HEAD WITH WASHER	2	
66	3TJ-14564-40	.O-RING	3	

FIG. 11 AIR INDUCTION SYSTEM

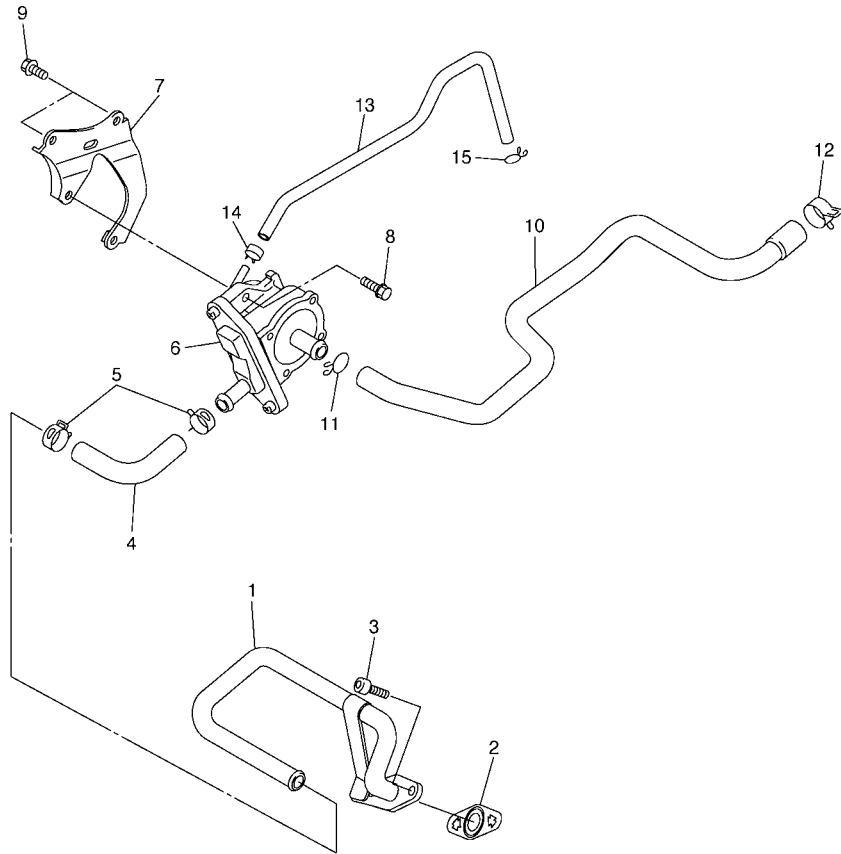

5TJE100-F110

REF. NO.	PART NO.	DESCRIPTION	STJM				REMARKS
1	5TJ-14871-10	PIPE 1	1				
2	5TJ-14815-00	GASKET	1				
3	91314-06016	BOLT	2				
4	5TJ-14881-10	HOSE, BEND 1	1				
5	90467-16063	CLIP	2				
6	5UM-14803-00	AIR INDUCTION SYSTEM ASSY	1				
7	5TJ-14834-E0	STAY	1				
8	90105-06107	BOLT, FLANGE	2				
9	90105-06105	BOLT, FLANGE	2				
10	5TJ-14882-10	HOSE, BEND 2	1				
11	90467-140A4	CLIP	1				
12	90467-17089	CLIP	1				
13	90445-082K4	HOSE (L250)	1				
14	90467-07138	CLIP	1				
15	90467-09006	CLIP	1				

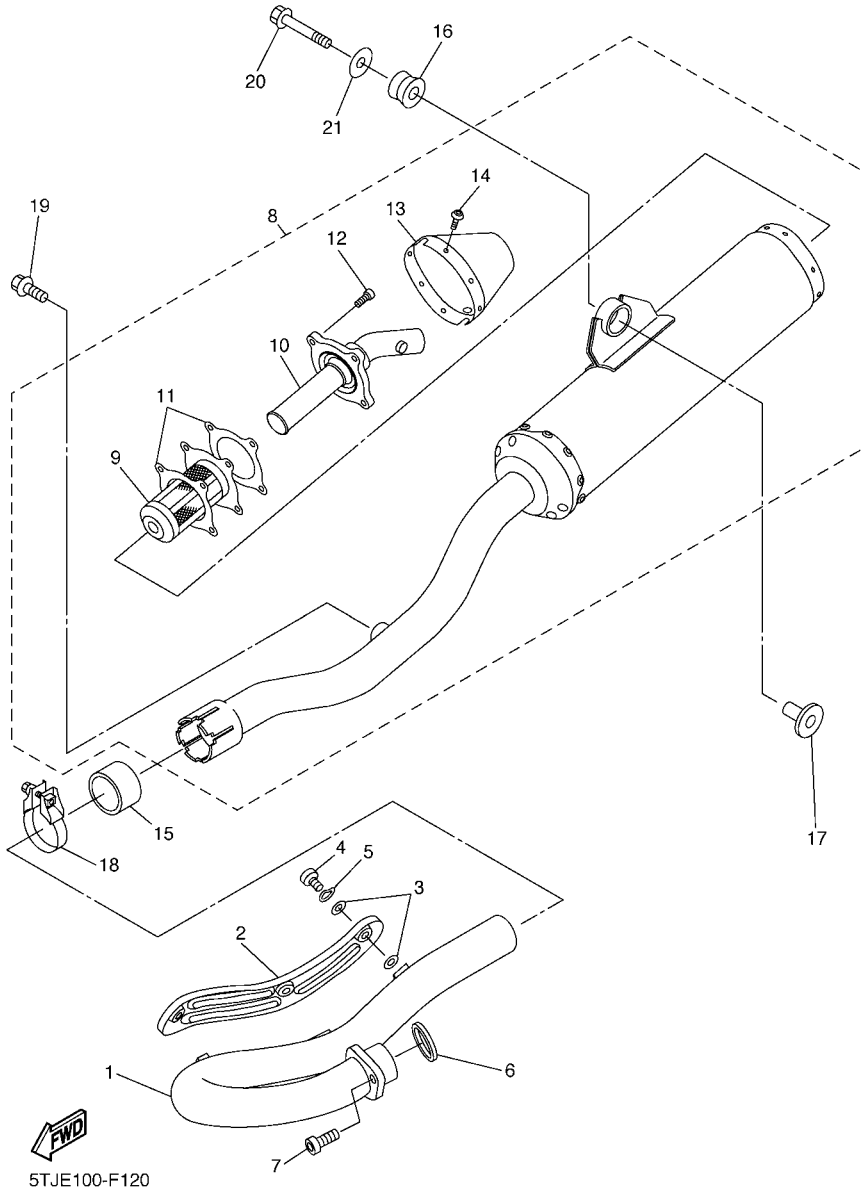
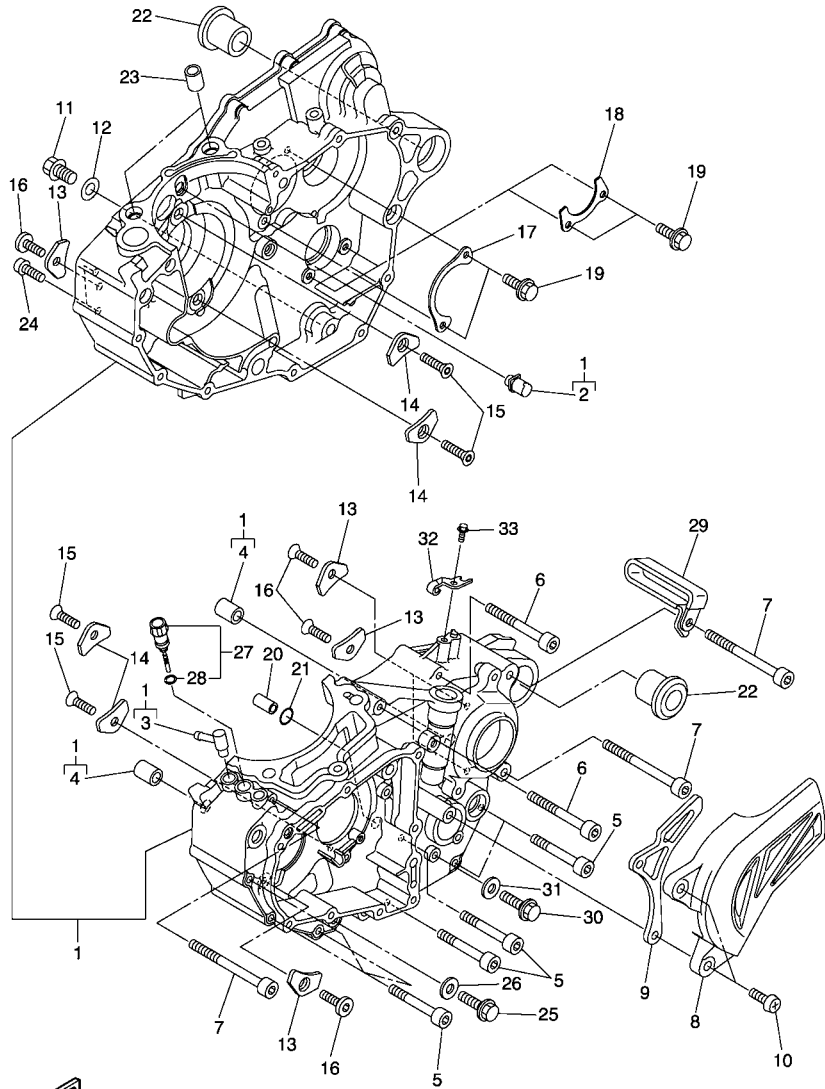

FIG. 12 EXHAUST

REF. NO.	PART NO.	DESCRIPTION	STJM				REMARKS
1	5TJ-14611-10	PIPE, EXHAUST 1	1				
2	5TA-14628-00	PROTECTOR, EXHAUST PIPE	1				
3	4BD-14766-00	WASHER, PROTECTOR	6				
4	98980-06008	SCREW, BIND	3				
5	90206-06090	WASHER, WAVE	3				
6	3VD-14613-01	GASKET, EXHAUST PIPE	1				
7	90110-08097	BOLT, HEXAGON SOCKET HEAD	1				
8	5TJ-14710-E0	MUFFLER ASSY 1	1				
9	5TJ-14780-00	.SPARK ARRESTER ASSY	1				
10	5TJ-14784-00	.PIPE, TAIL	1				
11	5TJ-14623-00	.GASKET, EXHAUST PIPE	2				
12	90110-05041	.BOLT, HEXAGON SOCKET HEAD	4				
13	5TJ-14799-00	.CAP	1				
14	92012-05008	.BOLT, BUTTON HEAD	6				
15	5PH-14714-00	GASKET, MUFFLER	1				
16	5BE-14747-00	DAMPER, MUFFLER	1				
17	90387-08081	COLLAR	1				
18	5BE-14788-00	BAND, SILENCER	1				
19	90105-08307	BOLT, FLANGE	1				
20	90105-08137	BOLT, FLANGE	1				
21	90201-08061	WASHER, PLATE	1				



5TJE100-F130

FIG. 13 CRANKCASE

REF. NO.	PART NO.	DESCRIPTION	5TJM				REMARKS
1	2S2-15100-10	CRANKCASE ASSY	1				
2	2S2-15155-10	.NOZZLE 3	1				
3	5XC-15373-00	.PIPE, BREATHER	1				
4	99530-14016	.PIN, DOWEL	2				
5	91312-06050	BOLT	7				
6	91312-06060	BOLT	2				
7	91312-06080	BOLT	3				
8	2S2-15421-10	COVER, CRANKCASE 2	1				
9	2S2-17466-00	GUIDE, CHAIN	1				
10	98502-06025	SCREW, PAN HEAD	2				
11	95022-10016	BOLT, FLANGE	1				
12	90430-10188	GASKET	1				
13	4JT-15381-01	PLATE, BEARING COVER	4				
14	5BE-15383-01	PLATE, BEARING COVER	4				
15	90151-06071	SCREW, COUNTERSUNK	4				
16	90149-06074	SCREW	4				
17	2S2-15388-00	PLATE, BEARING COVER	1				
18	2S2-18562-00	PLATE, STOPPER 2	1				
19	90105-06081	BOLT, FLANGE	4				
20	99530-10114	PIN, DOWEL	1				
21	93210-10197	O-RING	1				
22	90387-18007	COLLAR	2				
23	99530-14016	PIN, DOWEL	2				
24	91312-06030	BOLT	2				
25	95822-08016	BOLT, FLANGE	1				
26	90430-08119	GASKET	1				
27	2S2-1536A-00	PLUG, OIL LEVEL	1				

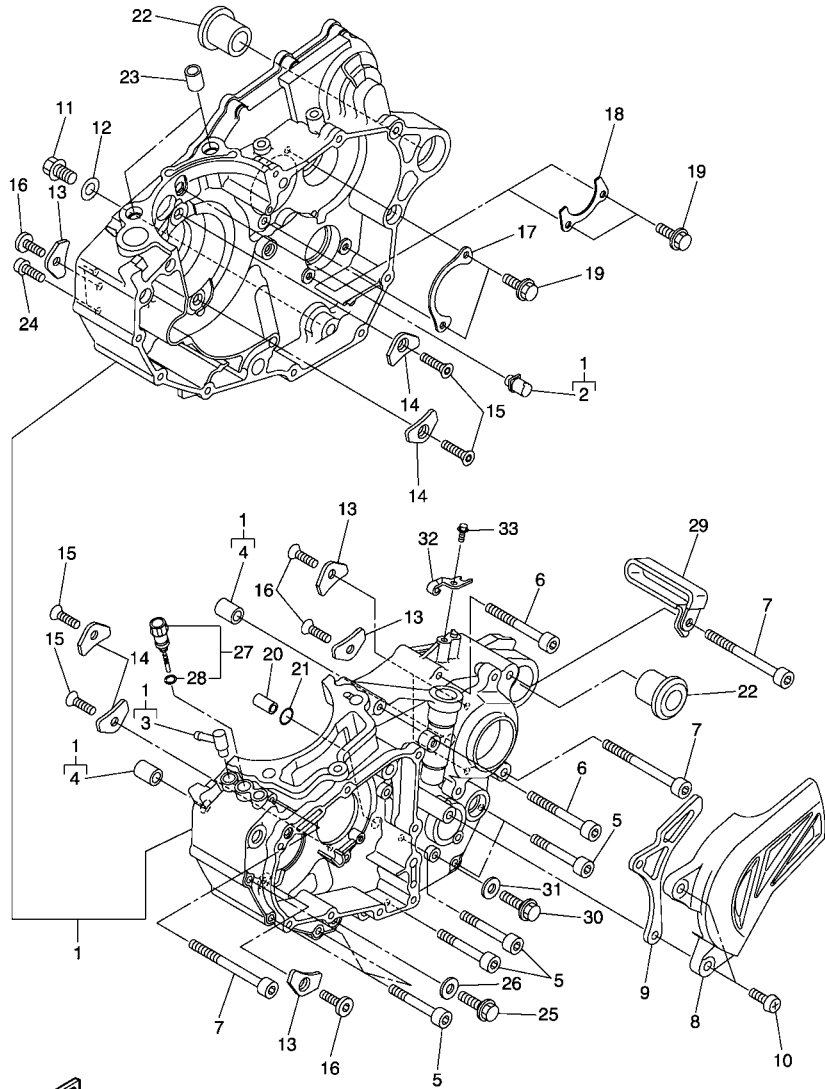

5TJE100-F130

FIG. 13 CRANKCASE

REF. NO.	PART NO.	DESCRIPTION	5TJM				REMARKS
28	93210-09165	.O-RING	1				
29	90461-10136	CLAMP	1				
30	95022-06012	BOLT, FLANGE	1				
31	90430-06014	GASKET	1				
32	5TA-15441-01	HOLDER, CLUTCH CABLE	1				
33	95022-06016	BOLT, FLANGE	1				
<hr/>							
<hr/>							
<hr/>							
<hr/>							
<hr/>							
<hr/>							
<hr/>							
<hr/>							
<hr/>							
<hr/>							

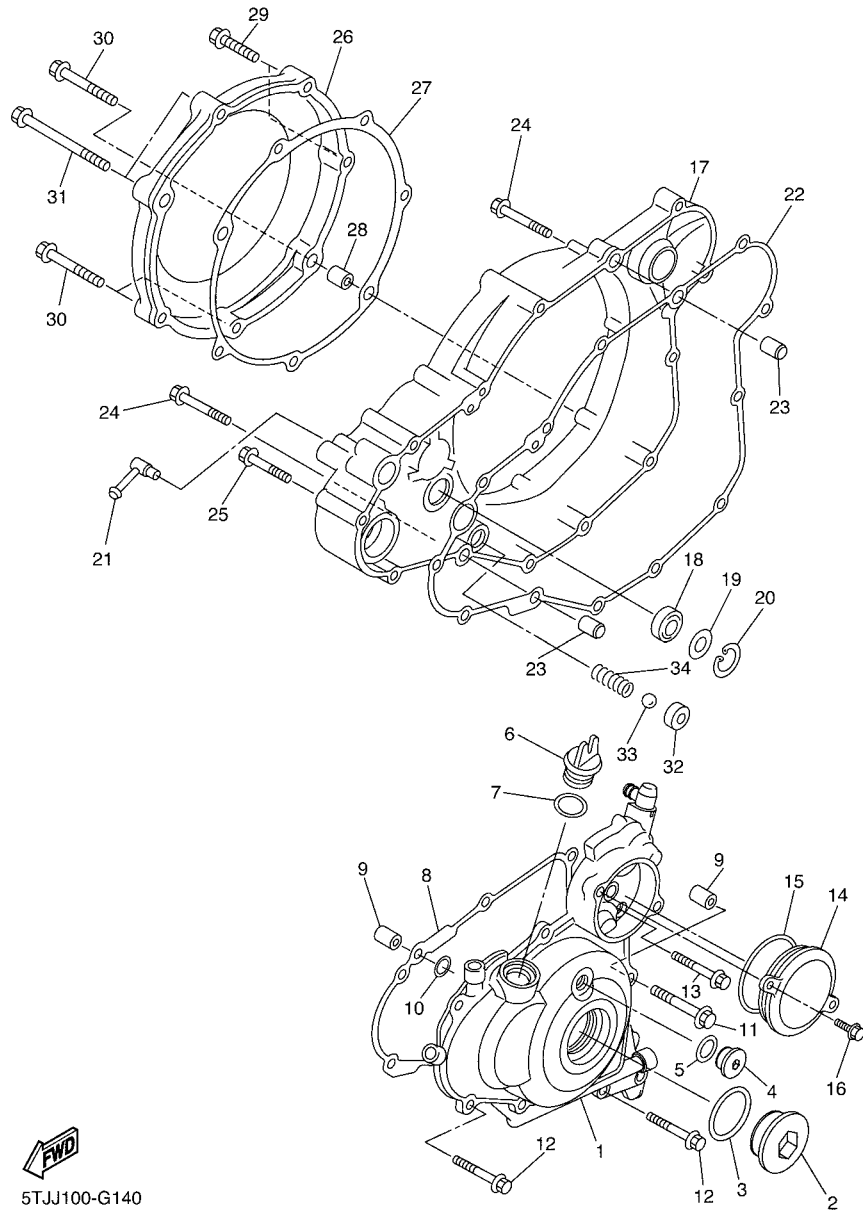

5TJJ100-G140

FIG. 14 CRANKCASE COVER 1

REF. NO.	PART NO.	DESCRIPTION	STJM				REMARKS
1	5TJ-15411-30	COVER, CRANKCASE 1	1				
2	90340-27003	PLUG, STRAIGHT SCREW	1				
3	93210-27370	O-RING	1				
4	90340-14003	PLUG, STRAIGHT SCREW	1				
5	93210-14369	O-RING	1				
6	3Y1-15363-00	PLUG, OIL	1				
7	93210-19123	O-RING	1				
8	2S2-15451-00	GASKET, CRANKCASE COVER 1	1				
9	99530-08016	PIN, DOWEL	2				
10	93210-08003	O-RING	1				
11	95022-06040	BOLT, FLANGE	1				
12	95022-06030	BOLT, FLANGE	6				
13	95022-06020	BOLT, FLANGE	1				
14	5TJ-1549B-20	COVER ASSY 2	1				
15	93210-58346	O-RING	1				
16	95022-06016	BOLT, FLANGE	2				
17	2S2-15431-00	COVER, CRANKCASE 3	1				
18	93101-14164	OIL SEAL	1				
19	90201-15701	WASHER, PLATE (T=1.0)	1				
20	99009-22500	CIRCLIP	1				
21	5XC-15373-00	PIPE, BREATHER	1				
22	2S2-15462-10	GASKET, CRANKCASE COVER 3	1				
23	91812-16001	PIN, DOWEL	2				
24	95022-06040	BOLT, FLANGE	2				
25	95022-06030	BOLT, FLANGE	6				
26	5TA-15415-20	COVER, GENERATOR	1				
27	5TA-15453-00	GASKET	1				

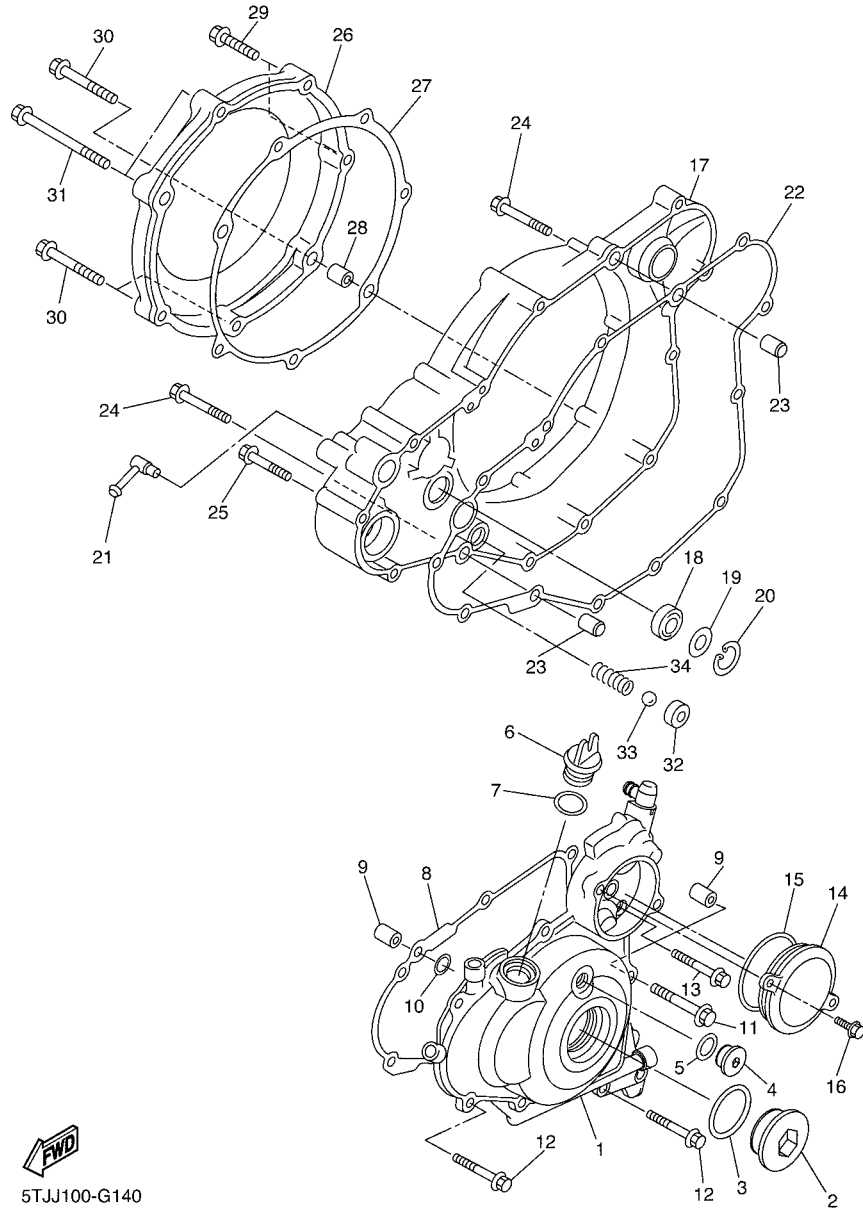

5TJJ100-G140

FIG. 14 CRANKCASE COVER 1

REF. NO.	PART NO.	DESCRIPTION	5TJM				REMARKS
28	99530-08016	PIN, DOWEL	2				
29	95022-06030	BOLT, FLANGE	2				
30	95022-06040	BOLT, FLANGE	3				
31	95022-06080	BOLT, FLANGE	2				
32	583-13113-00	SEAT, CHECK BALL	1				
33	93503-08007	BALL	1				
34	90501-043E0	SPRING, COMPRESSION	1				

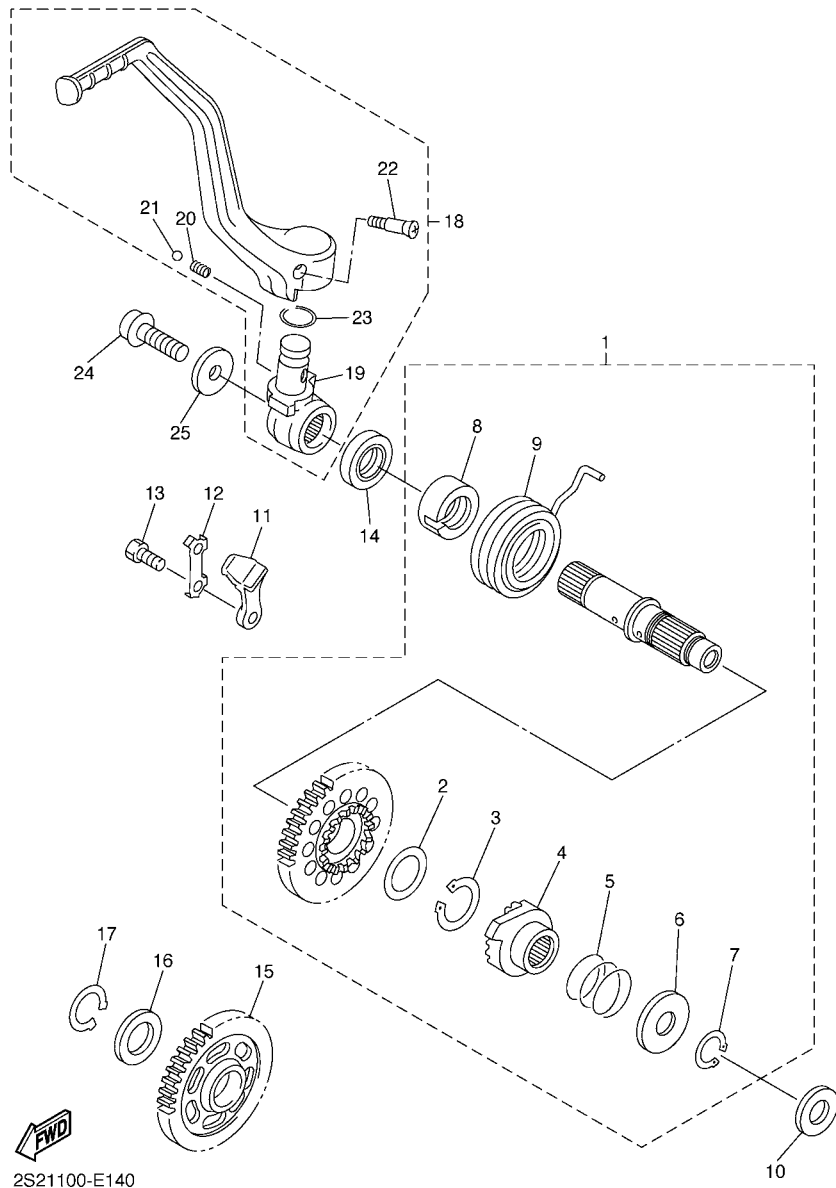
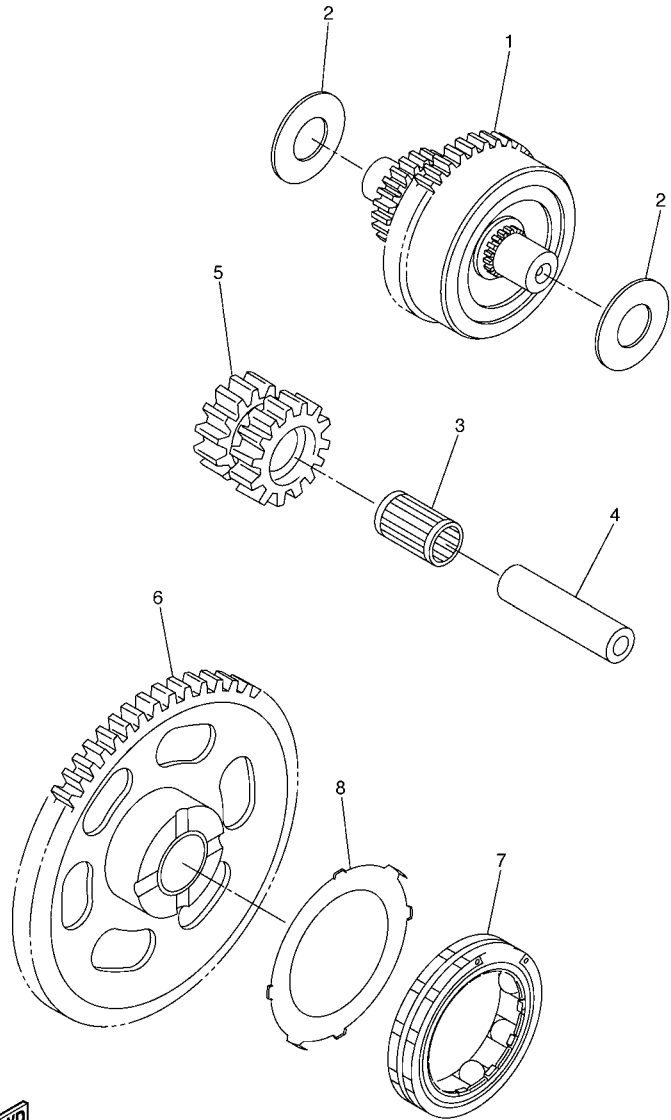

FIG. 15 STARTER

REF. NO.	PART NO.	DESCRIPTION	STJM				REMARKS
1	2S2-15601-00	KICK SHAFT ASSY	1				
2	90201-20685	.WASHER, PLATE (T=0.5)	1				
3	93410-20038	.CIRCLIP	1				
4	2S2-15671-00	.WHEEL, RATCHET	1				
5	90501-160A2	.SPRING, COMPRESSION	1				
6	90201-167P7	.WASHER, PLATE	1				
7	99009-16400	.CIRCLIP	1				
8	5GR-15664-00	.GUIDE, SPRING	1				
9	90508-305B0	.SPRING, TORSION	1				
10	90201-162H4	WASHER, PLATE	1				
11	5SG-15668-00	STOPPER	1				
12	214-15686-00	WASHER, LOCK	1				
13	90101-06044	BOLT	2				
14	93102-20108	OIL SEAL	1				
15	5TA-15651-00	GEAR, KICK IDLE	1				
16	90201-20685	WASHER, PLATE (T=0.5)	1				
17	99009-20400	CIRCLIP	1				
18	2S2-15620-01	KICK CRANK ASSY	1				
19	5XD-15621-00	.BOSS, KICK CRANK	1				
20	90501-147A5	.SPRING, COMPRESSION	1				
21	93507-32009	.BALL	1				
22	90152-06010	.SCREW, COUNTERSUNK	1				
23	93210-17570	.O-RING	1				
24	90110-08087	BOLT, HEXAGON SOCKET HEAD	1				
25	90201-08047	WASHER, PLATE	1				



5TJE100-F160

FIG. 16 STARTER CLUTCH

REF. NO.	PART NO.	DESCRIPTION	5TJM				REMARKS
1	5TJ-15560-20	DAMPER ASSY	1				
2	90201-105A8	WASHER, PLATE	2				
3	93310-212R6	BEARING	1				
4	4GY-15521-00	SHAFT 1	1				
5	5TJ-15517-00	GEAR, IDLER 2	1				
6	5TG-15515-01	GEAR 3	1				
7	5UM-15570-00	STARTER CLUTCH ASSY	1				
8	5VY-15586-00	PLATE, STARTER CLUTCH ASSY	1				

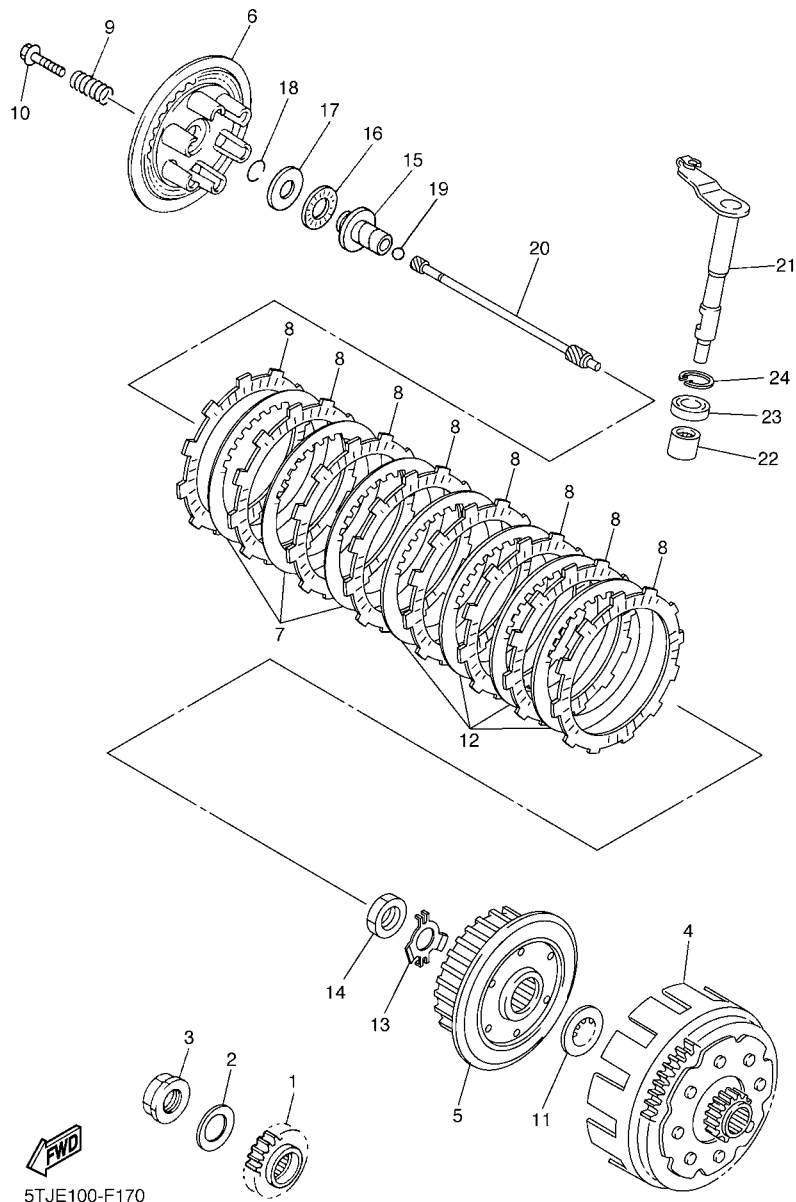

5TJE100-F170

FIG. 17 CLUTCH

REF. NO.	PART NO.	DESCRIPTION	5TJM				REMARKS
1	2S2-16111-60	GEAR, PRIMARY DRIVE	1				
2	90208-25045	WASHER, CONICAL SPRING	1				
3	90179-20009	NUT	1				
4	5XD-16150-60	PRIMARY DRIVEN GEAR COMP.	1				
5	5TA-16371-10	BOSS, CLUTCH	1				
6	5JG-16351-00	PLATE, PRESSURE 1	1				
7	4X7-16325-00	PLATE, CLUTCH 2	3				
8	5TA-16321-00	PLATE, FRICTION	8				
9	90501-237L0	SPRING, COMPRESSION	6				
10	90159-06092	SCREW, WITH WASHER	6				
11	5XD-16154-00	PLATE, THRUST 1	1				
12	1TA-16325-00	PLATE, CLUTCH 2	4				
13	90215-20005	WASHER, LOCK	1				
14	90170-20327	NUT	1				
15	5JG-16356-00	ROD, PUSH 1	1				
16	93340-21505	BEARING	1				
17	90201-125L6	WASHER, PLATE	1				
18	93440-10085	CIRCLIP	1				
19	93511-32027	BALL	1				
20	2S2-16357-00	ROD, PUSH 2	1				
21	5TJ-16381-20	PUSH LEVER COMP.	1				
22	93317-11287	BEARING	1				
23	93102-12224	OIL SEAL	1				
24	99009-20500	CIRCLIP	1				

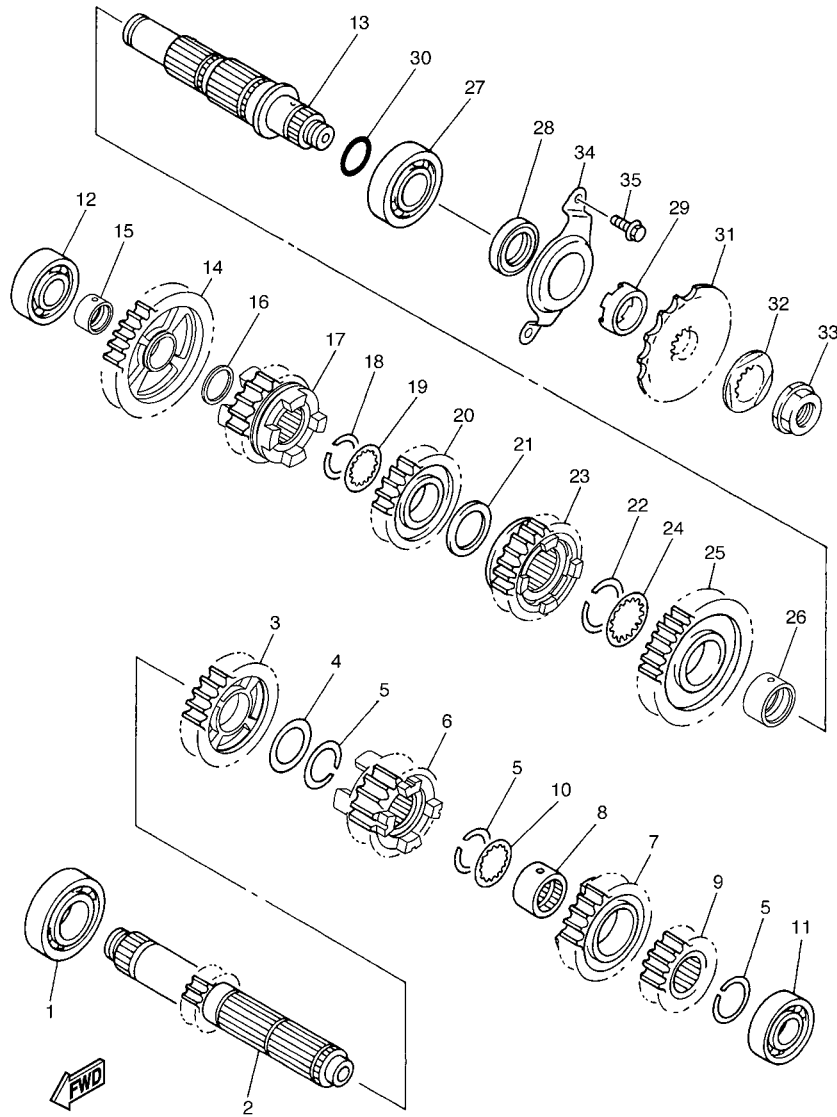

2S21100-E160

FIG. 18 TRANSMISSION

REF. NO.	PART NO.	DESCRIPTION	STJM				REMARKS
1	93306-20532	BEARING	1				
2	5TJ-17411-20	AXLE,MAIN(12T)	1				
3	5TJ-17151-20	GEAR, 5TH PINION(25T)	1				
4	90201-253K0	WASHER, PLATE (T=1.0)	1				
5	93440-25084	CIRCLIP	3				
6	5TJ-17131-20	GEAR, 3RD PINION(16T)	1				
7	5TJ-17141-20	GEAR, 4TH PINION (20T)	1				
8	90387-21005	COLLAR	1				
9	5TJ-17121-20	GEAR, 2ND PINION(15T)	1				
10	90209-21332	WASHER	1				
11	93306-00431	BEARING	1				
12	93306-00426	BEARING	1				
13	2S2-17402-00	DRIVE AXLE ASSY	1				
14	5TJ-17211-20	GEAR, 1ST WHEEL(29T)	1				
15	90387-20028	COLLAR	1				
16	90201-203E7	WASHER, PLATE	1				
17	5TJ-17251-20	GEAR, 5TH WHEEL(21T)	1				
18	93440-25084	CIRCLIP	1				
19	90209-21332	WASHER	1				
20	5TJ-17231-20	GEAR, 3RD WHEEL(21T)	1				
21	90201-253K0	WASHER, PLATE (T=1.0)	1				
22	93440-28062	CIRCLIP	1				
23	5TJ-17241-20	GEAR, 4TH WHEEL(21T)	1				
24	90209-26348	WASHER	1				
25	5TJ-17221-20	GEAR, 2ND WHEEL(26T)	1				
26	90387-28012	COLLAR	1				
27	93306-205A5	BEARING	1				

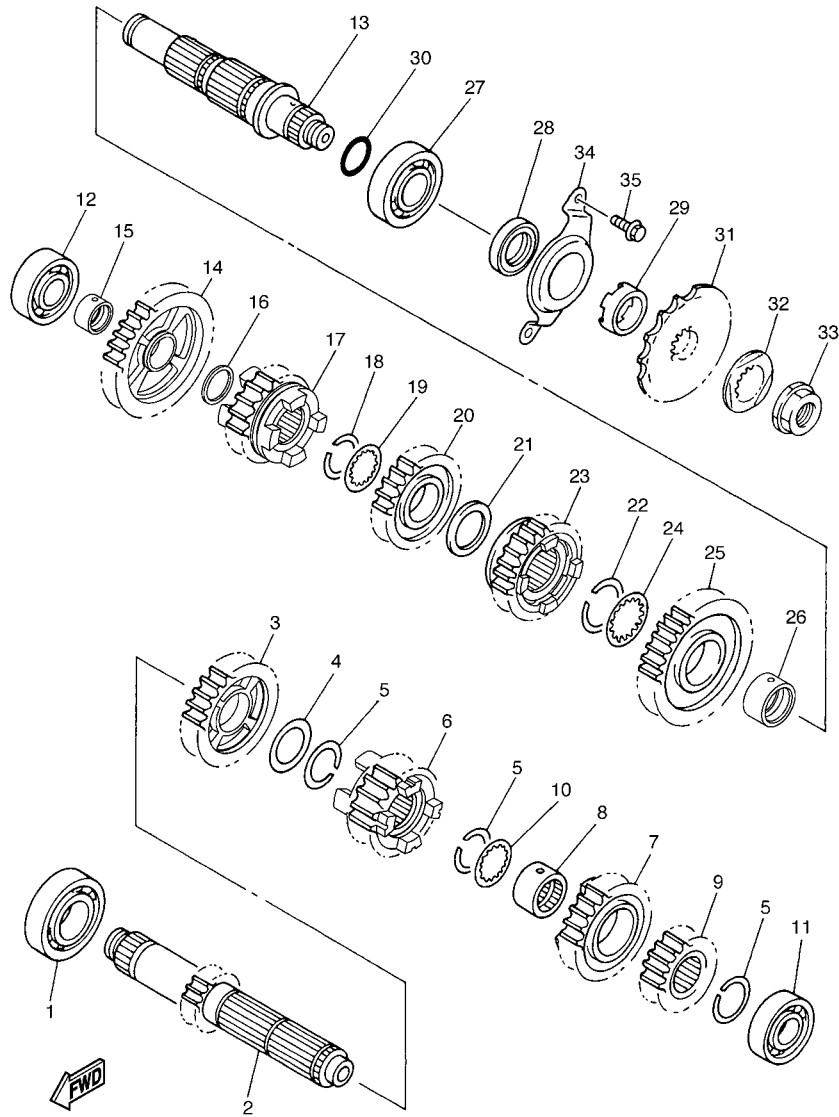

2S21100-E160

FIG. 18 TRANSMISSION

REF. NO.	PART NO.	DESCRIPTION	ST./M				REMARKS
28	93102-32480	OIL SEAL	1				
29	90387-2513F	COLLAR	1				
30	93210-22164	O-RING	1				
31	9383E-13233	SPROCKET, DRIVE (13T)	1				STD FOR ZAF
	9383E-14215	SPROCKET, DRIVE (14T)	1				UR
32	90215-21003	WASHER, LOCK	1				
33	90179-20001	NUT	1				
34	2S2-17471-00	PLATE, COVER	1				
35	90105-06081	BOLT, FLANGE	2				

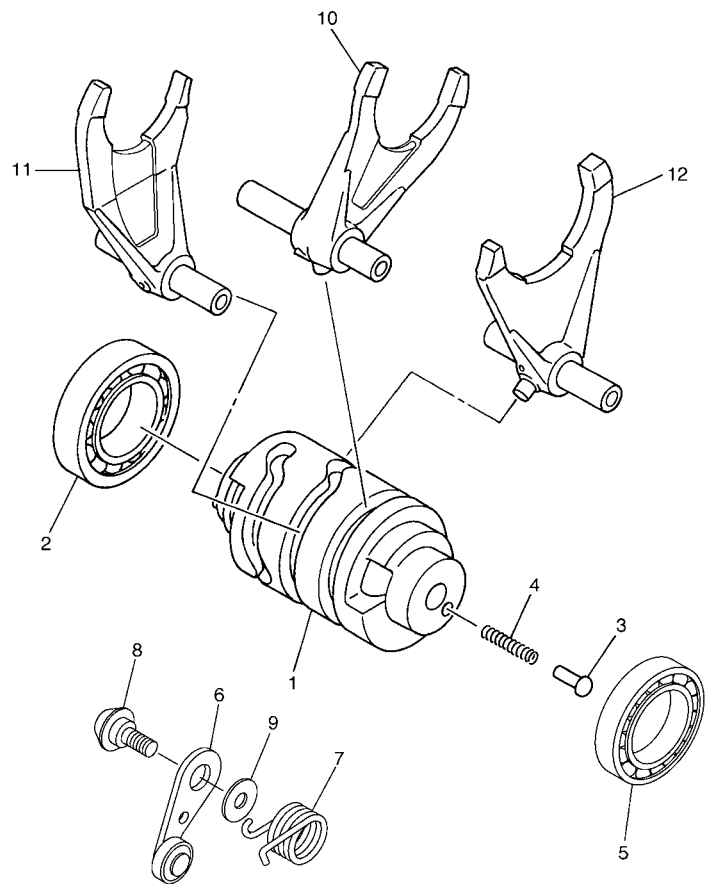

2S27100-F170

FIG. 19 SHIFT CAM & FORK

REF. NO.	PART NO.	DESCRIPTION	STJM				REMARKS
1	5NL-18541-00	CAM, SHIFT	1				
2	93306-90509	BEARING	1				
3	278-18542-00	POINT, NEUTRAL	1				
4	90501-06022	SPRING, COMPRESSION	1				
5	93306-80501	BEARING	1				
6	2S2-18140-10	STOPPER LEVER ASSY	1				
7	90508-26021	SPRING, TORSION	1				
8	90109-06198	BOLT	1				
9	90201-06013	WASHER, PLATE	1				
10	2S2-18501-00	FORK, SHIFT 1	1				
11	2S2-18502-00	FORK, SHIFT 2	1				
12	5BE-18503-00	FORK, SHIFT 3	1				

FIG. 20 SHIFT SHAFT

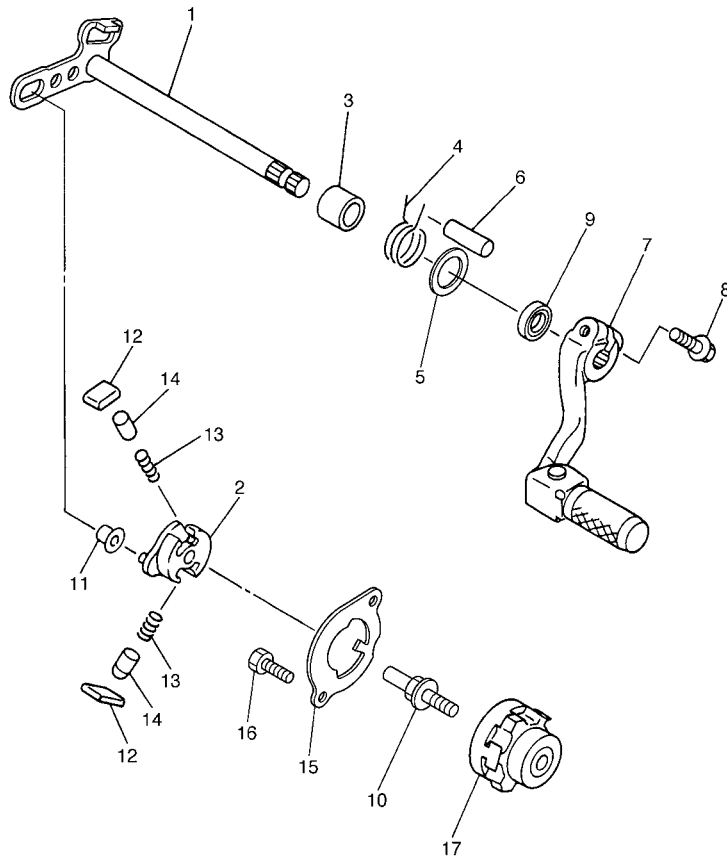

REF. NO.	PART NO.	DESCRIPTION	QTY	UNIT	REMARKS
1	2S2-18101-00	SHIFT SHAFT ASSY	1		
2	5MW-18122-01	LEVER, SHIFT 2	1		
3	90387-124F4	COLLAR	1		
4	90508-29021	SPRING, TORSION	1		
5	90201-127E1	WASHER, PLATE	1		
6	93608-33002	PIN, DOWEL	1		
7	5XC-18110-00	SHIFT PEDAL ASSY	1		
8	95022-06020	BOLT, FLANGE	1		
9	93102-12224	OIL SEAL	1		
10	3XJ-18173-10	PIN, SHIFT	1		
11	3XJ-18178-00	ROLLER, SHIFT LEVER	1		
12	3XJ-18182-00	PAWL, SHIFTER	2		
13	90501-052G5	SPRING, COMPRESSION	2		
14	3XJ-18184-00	PIN, PAWL	2		
15	5TJ-18172-00	GUIDE, SHIFT	1		
16	90101-06041	BOLT	2		
17	2S2-18185-00	SEGMENT	1		



2S21100-E180

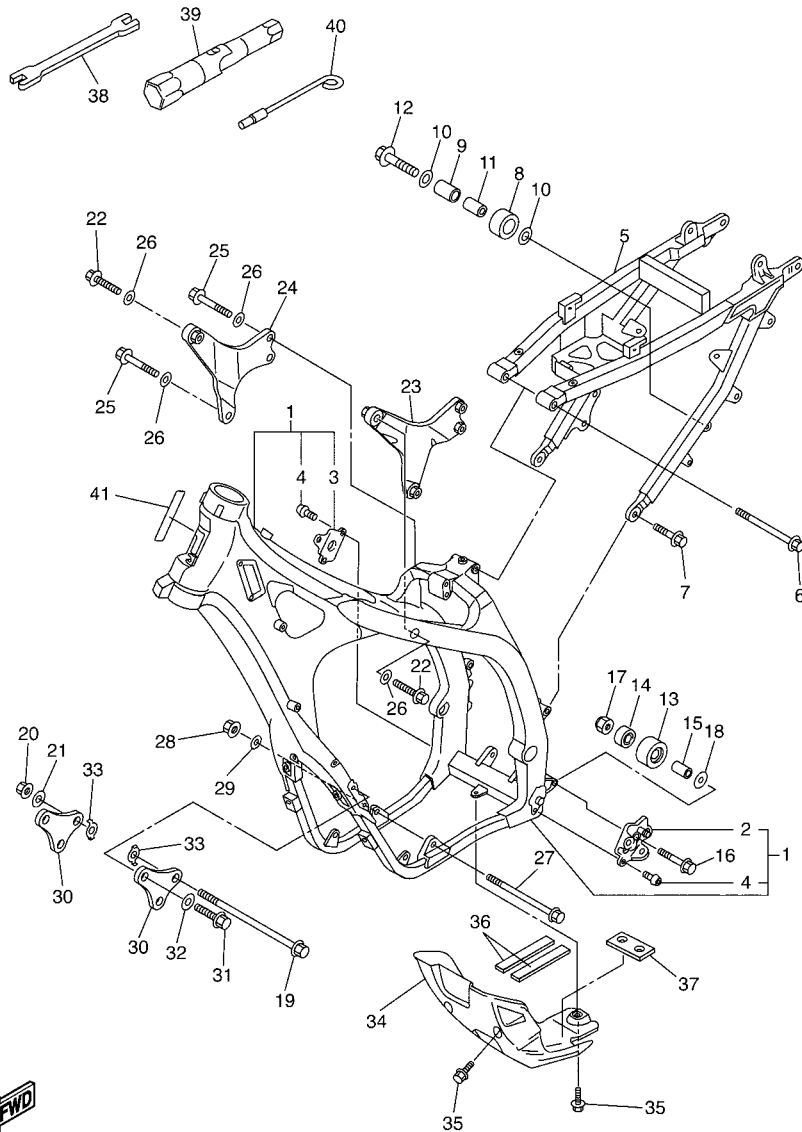

5TJM100-G210

FIG. 21 FRAME

REF. NO.	PART NO.	DESCRIPTION	5TJM				REMARKS
1	5TJ-21101-E0	FRONT FRAME COMP.	1				
2	5UM-21447-E0	.BRACKET, FOOTREST	1				
3	1C3-21448-10	.BRACKET, FOOTREST	1				
4	90149-10031	.SCREW	4				
5	5UM-21190-E0	REAR FRAME COMP.	1				
6	90105-08156	BOLT, FLANGE	1				
7	90105-08307	BOLT, FLANGE	2				
8	30X-22178-00	TENSIONER	1				
9	4V4-22184-00	BUSH	1				
10	90201-08045	WASHER, PLATE	2				
11	90387-08041	COLLAR	1				
12	95022-08040	BOLT, FLANGE	1				
13	3JD-22178-20	TENSIONER	1				
14	93300-60839	BEARING	1				
15	90387-086N4	COLLAR	1				
16	90105-08133	BOLT, FLANGE	1				
17	90185-08009	NUT, SELF-LOCKING	1				
18	90201-08043	WASHER, PLATE	1				
19	90105-10193	BOLT, FLANGE	1				
20	90179-10658	NUT	1				
21	90201-10045	WASHER, PLATE	1				
22	90105-10189	BOLT, FLANGE	2				
23	2S2-21425-70	BRACKET, REAR UPPER 1	1				
24	2S2-21426-70	BRACKET, REAR UPPER 2	1				
25	90105-10191	BOLT, FLANGE	3				
26	90201-10045	WASHER, PLATE	5				
27	90105-10176	BOLT, FLANGE	1				

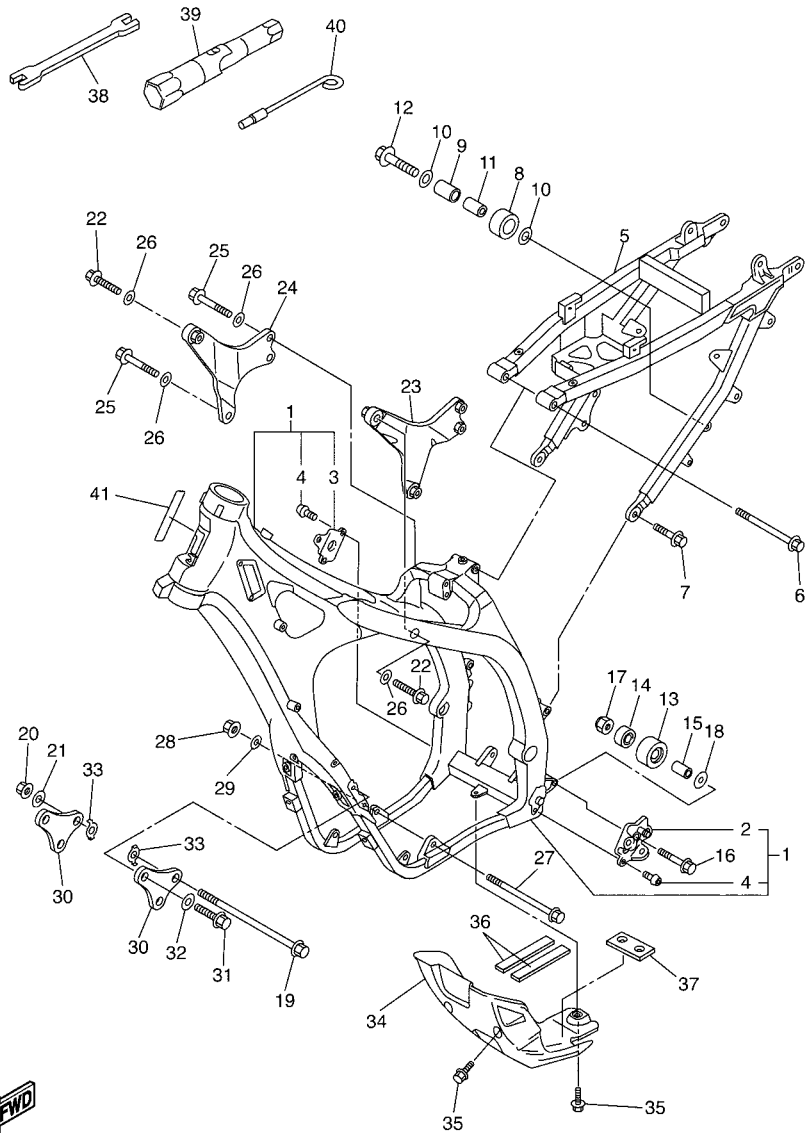

5TJM100-G210

FIG. 21 FRAME

REF. NO.	PART NO.	DESCRIPTION	5TJM				REMARKS
28	90179-10658	NUT	1				
29	90201-10045	WASHER, PLATE	1				
30	2S2-21417-00	BRACKET, FRONT LOWER 1	2				
31	90105-08143	BOLT, FLANGE	4				
32	92902-08200	WASHER	4				
33	5XC-21456-90	PLATE, PATCH	2				
34	5UM-2147A-E0	GUARD, ENGINE 1	1				
35	90119-06166	BOLT, WITH WASHER	3				
36	5UM-21486-E0	DAMPER 2	2				
37	5TJ-21485-E0	DAMPER, RUBBER 1	1				
38	5ET-28166-10	WRENCH, HEXAGON	1				
39	5TA-2814F-00	BOX, SPARK PLUG	1				
40	5XC-28116-00	TOOL, SPECIAL	1				
41	5UM-21268-E0	SEAL	1				

FIG. 22 FENDER

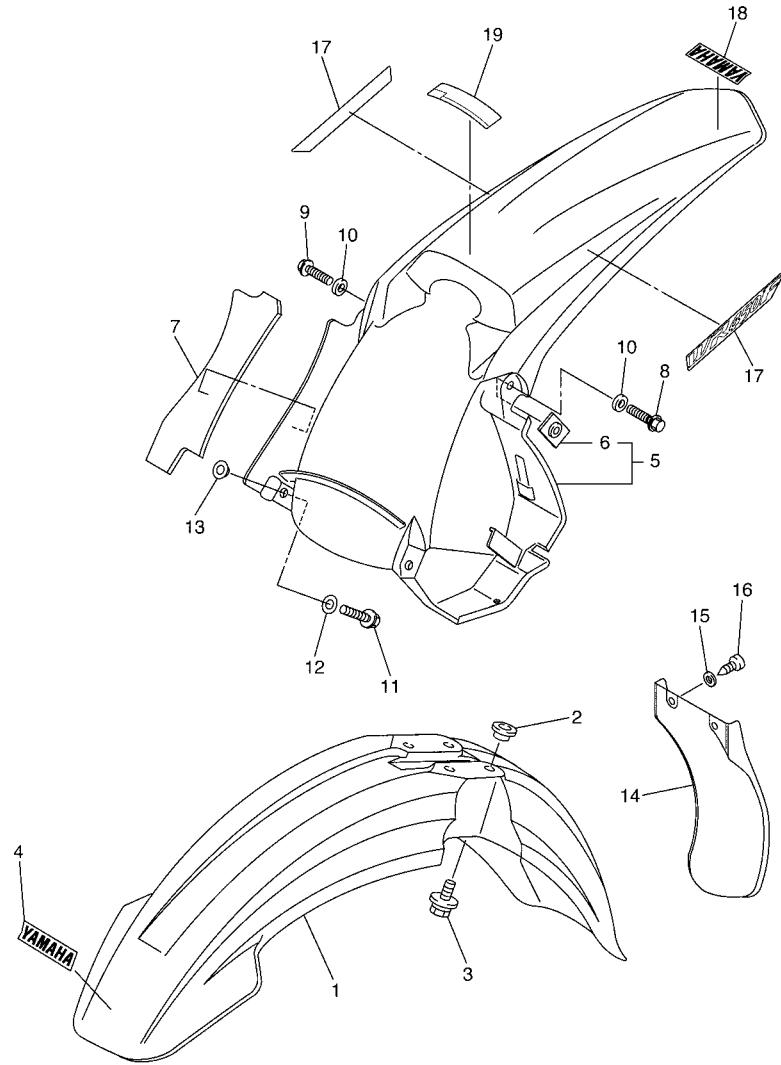

5TJM100-G220

REF. NO.	PART NO.	DESCRIPTION	5TJM				REMARKS
1	1C3-21511-51	FENDER, FRONT	1				
2	90387-06090	COLLAR	4				
3	90119-06147	BOLT, WITH WASHER	4				
4	4ES-2153E-01	EMBLEM, YAMAHA	1				
5	5UM-21610-E0	REAR FENDER COMP.	1				
6	5XE-21635-10	.NUT, REAR FENDER	2				
7	5UM-2174T-E0	INSULATOR, SIDE COVER 2	1				
8	90105-06127	BOLT, FLANGE	1				
9	90105-06100	BOLT, FLANGE	1				
10	90201-06032	WASHER, PLATE	2				
11	90105-06106	BOLT, FLANGE	2				
12	90201-06571	WASHER, PLATE	2				
13	90387-06009	COLLAR	2				
14	5TA-21642-00	GUARD, FLAP	1				
15	90201-06084	WASHER, PLATE	2				
16	97702-60016	SCREW, TAPPING	2				
17	5TJ-2163G-20	EMBLEM 1	2				
18	5UM-2153E-00	EMBLEM, YAMAHA	1				
19	5PA-21568-00	LABEL, WARNING	1				

FIG. 23 SIDE COVER

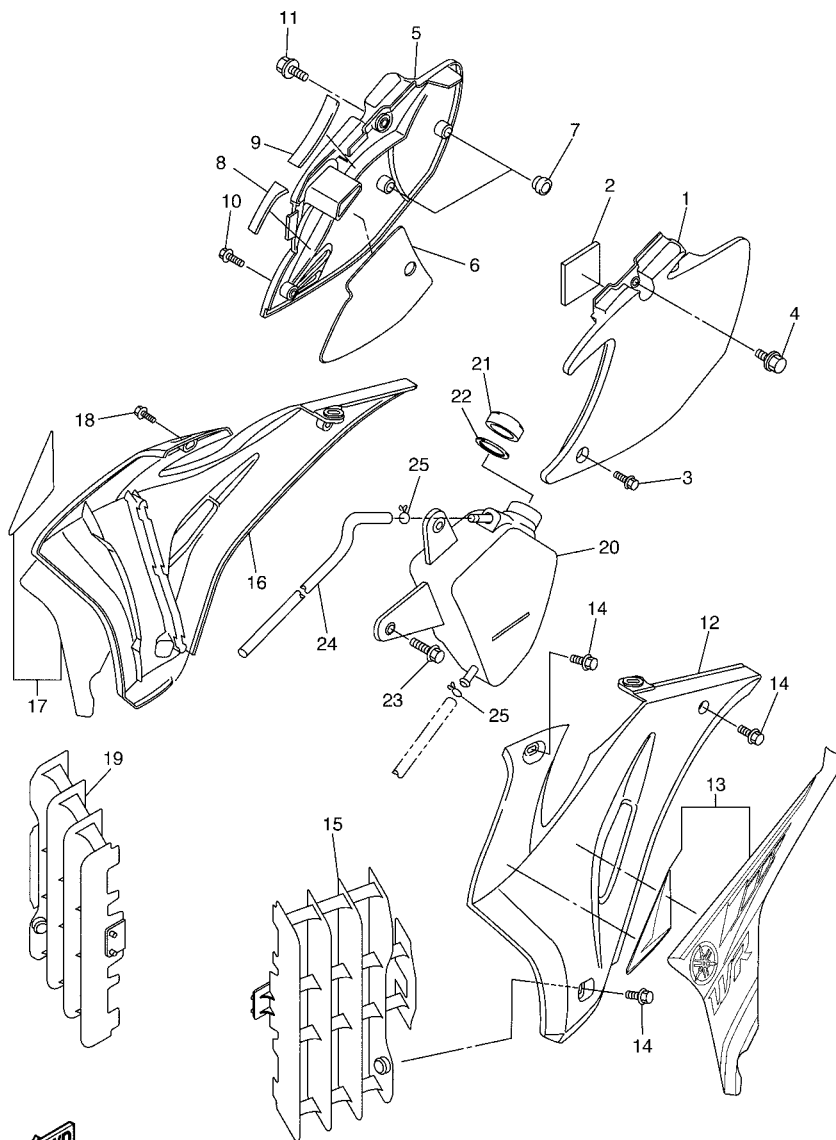

FWD
5TJJ100-G230

REF. NO.	PART NO.	DESCRIPTION	STJM				REMARKS
1	5UM-21711-E0	COVER, SIDE 1	1				
2	5UM-21717-E0	DAMPER	1				
3	90105-06103	BOLT, FLANGE	1				
4	90119-08095	BOLT, WITH WASHER	1				
5	5UM-21721-E0	COVER, SIDE 2	1				
6	5UM-2174A-E0	INSULATOR, SIDE COVER	1				
7	5XC-21719-90	GROMMET	2				
8	5UM-2172S-E0	INSULATOR 3	1				
9	5UM-2173S-E0	INSULATOR 4	1				
10	90105-06103	BOLT, FLANGE	1				
11	90119-08095	BOLT, WITH WASHER	1				
12	5UM-21730-E0	SIDE COVER ASSY 3	1				
13	5TJ-2173L-00	GRAPHIC SET 1	1				
14	90105-06064	BOLT, FLANGE	4				
15	5TJ-2172A-E0	PANEL 1	1				
16	5UM-21740-E0	SIDE COVER ASSY 4	1				
17	5TJ-2174L-00	GRAPHIC SET 2	1				
18	90105-06064	BOLT, FLANGE	4				
19	2S2-2172A-80	PANEL 1	1				
20	5UM-21860-E0	TANK ASSY	1				
21	26H-21875-00	CAP	1				
22	26H-21874-00	GASKET	1				
23	90119-06146	BOLT, WITH WASHER	1				
24	5UM-1244J-E0	HOSE 6	1				
25	90467-090A2	CLIP	3				

FIG. 24 REAR ARM

REF. NO.	PART NO.	DESCRIPTION	QTY	REMARKS
1	2S2-22110-70	REAR ARM COMP.	1	
2	90151-04003	SCREW, COUNTERSUNK	4	
3	1P8-22355-00	PATCH	2	
4	93317-22262	BEARING	4	
5	93342-22217	BEARING	2	
6	93106-22002	OIL SEAL	2	
7	93109-28043	OIL SEAL	2	
8	90387-18012	COLLAR	2	
9	90387-18004	COLLAR	2	
10	2S2-22151-70	SEAL, GUARD	1	
11	1C3-22969-90	SCREW, 1	4	
12	5UM-22199-E0	SUPPORT, CHAIN	1	
13	2S2-22128-70	COVER, THRUST 1	1	
14	90105-06104	BOLT, FLANGE	2	
15	90179-06028	NUT	2	
16	90105-06105	BOLT, FLANGE	1	
17	1C3-22141-10	SHAFT, PIVOT	1	
18	90185-16002	NUT, SELF-LOCKING	1	
19	90201-16018	WASHER, PLATE	1	
20	5XC-2217A-90	ARM, RELAY	1	
21	93315-32166	BEARING	4	
22	93109-25001	OIL SEAL	4	
23	90387-16010	COLLAR	2	
24	90209-16011	WASHER	4	
25	90201-21014	WASHER, PLATE	4	
26	5XC-2217F-90	ROD, CONNECTING 1	1	
27	93315-32269	BEARING	2	

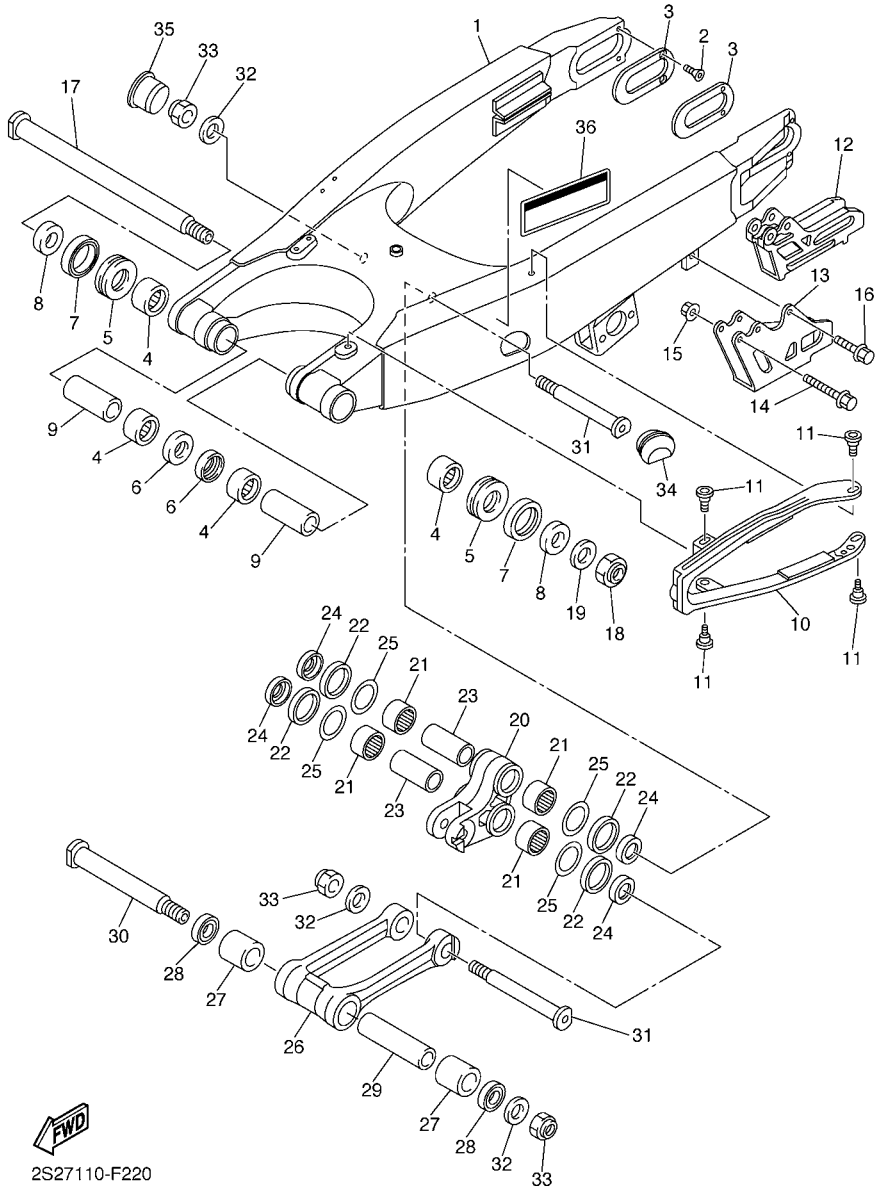

2S27110-F220

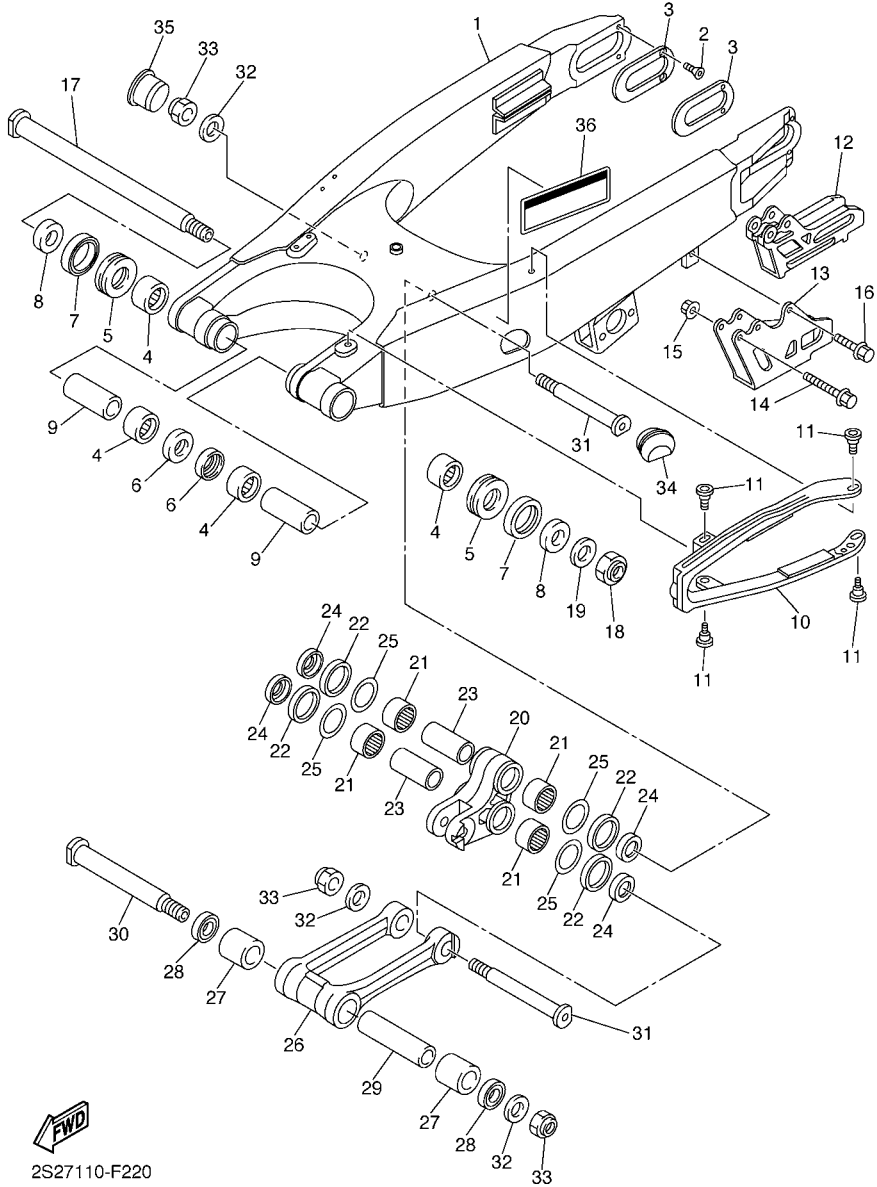

2S27110-F220

FIG. 24 REAR ARM

REF. NO.	PART NO.	DESCRIPTION	QTY	UNIT	REMARKS
28	93109-22019	OIL SEAL	2		
29	90387-14009	COLLAR	1		
30	5XC-22121-91	SHAFT 1	1		
31	1C3-22122-00	SHAFT 2	2		
32	90201-14020	WASHER, PLATE	3		
33	90185-14010	NUT, SELF-LOCKING	3		
34	1C3-2135F-00	COVER	1		
35	1C3-2139R-00	COVER 2	1		
36	3RV-21668-A0	LABEL, TIRE	1		

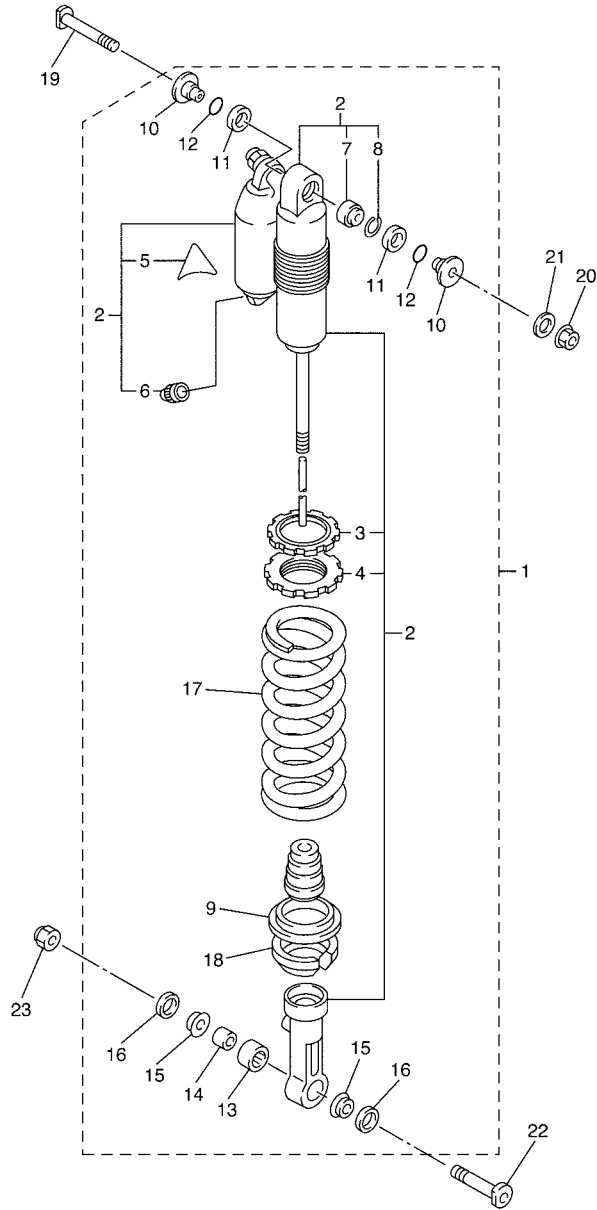

FWD
5TJM100-G250

FIG. 25 REAR SUSPENSION

REF. NO.	PART NO.	DESCRIPTION	STJM				REMARKS
1	5TJ-22210-G0	SHOCK ABSORBER ASSY, REAR	1				
2	5TJ-22201-G0	.DAMPER SUB ASSY	1				
3	3SP-22234-00	..GUIDE, SPRING 3	1				
4	3SP-22213-00	..SEAT, SPRING UPPER	1				
5	4AA-22259-40	..LABEL, WARNING	1				
6	509-23184-L0	..CAP, AIR VALVE	1				
7	4JX-22226-00	..BUSH, SHOCK ABSORBER LOWER	1				
8	5DH-23183-00	..CIRCLIP	1				
9	5MV-22224-00	.GUIDE, SPRING 2	1				
10	1C3-22253-50	.COLLAR, DISTANCE	2				
11	3JE-22475-00	.SEAL, DUST	2				
12	4EW-22474-00	.SEAL, RING	2				
13	5UN-22176-00	.BEARING	1				
14	5MV-22184-00	.BUSH	1				
15	5MV-22253-00	.COLLAR, DISTANCE	2				
16	5NY-22475-00	.SEAL, DUST	2				
17	5UN-22212-60	.SPRING (K=54N/MM)	1				
18	5XE-22214-00	.GUIDE, SPRING 1	1				
19	5XE-22242-00	BOLT 2	1				
20	95602-10200	NUT, U FLANGE	1				
21	92902-10200	WASHER	1				
22	5NY-22241-00	BOLT 1	1				
23	90185-10012	NUT, SELF-LOCKING	1				

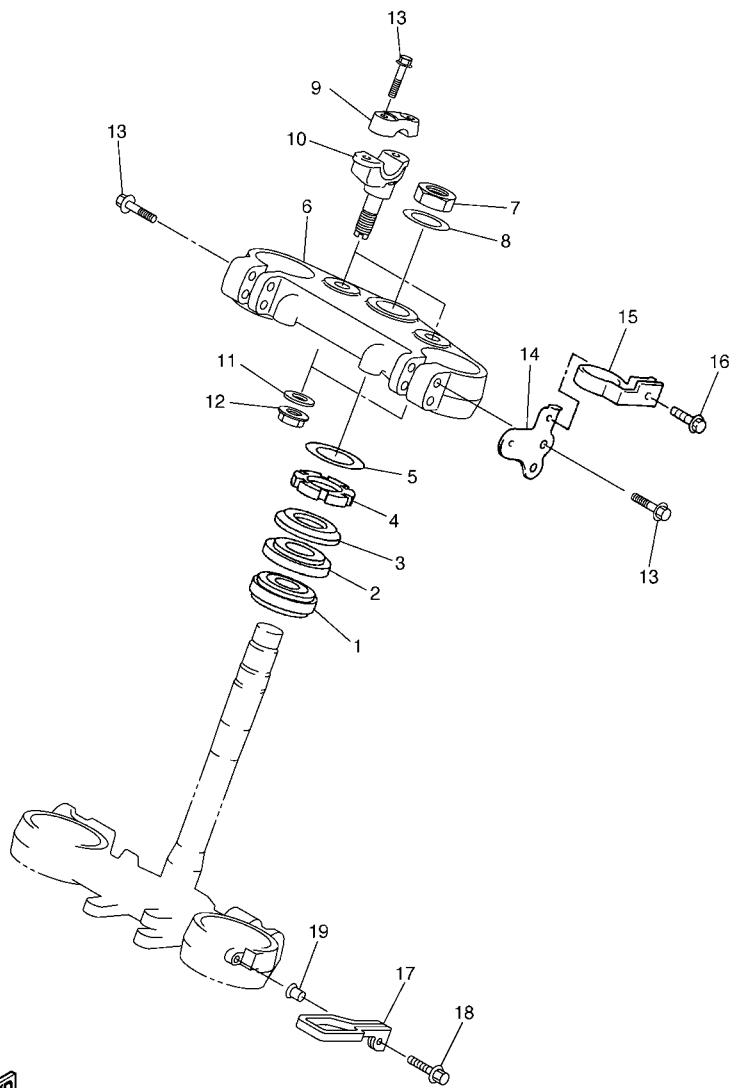

FWD
5TJE100-F260

FIG. 26 STEERING

REF. NO.	PART NO.	DESCRIPTION	STJM				REMARKS
1	93332-00081	BEARING	1				
2	93332-00068	BEARING	1				
3	4EW-23416-00	COVER, BALL RACE 2	1				
4	90179-28003	NUT	1				
5	90201-286K9	WASHER, PLATE (T1.0)	1				
6	5UM-23435-E1	CROWN, HANDLE	1				
7	90170-24003	NUT	1				
8	90201-24016	WASHER, PLATE	1				
9	5XC-23441-90	HOLDER, HANDLE UPPER	2				
10	5UM-23442-E0	HOLDER, HANDLE LOWER	2				
11	92902-10200	WASHER	2				
12	95602-10200	NUT, U FLANGE	2				
13	90105-08154	BOLT, FLANGE	8				
14	5UM-2831V-E0	STAY, HEAD LIGHT 1	1				
15	5TJ-2331E-80	GUIDE, CABLE	1				
16	90105-05016	BOLT, FLANGE	1				
17	5TJ-23389-80	GUIDE, CABLE	1				
18	90105-06107	BOLT, FLANGE	1				
19	90387-06104	COLLAR	1				

D10

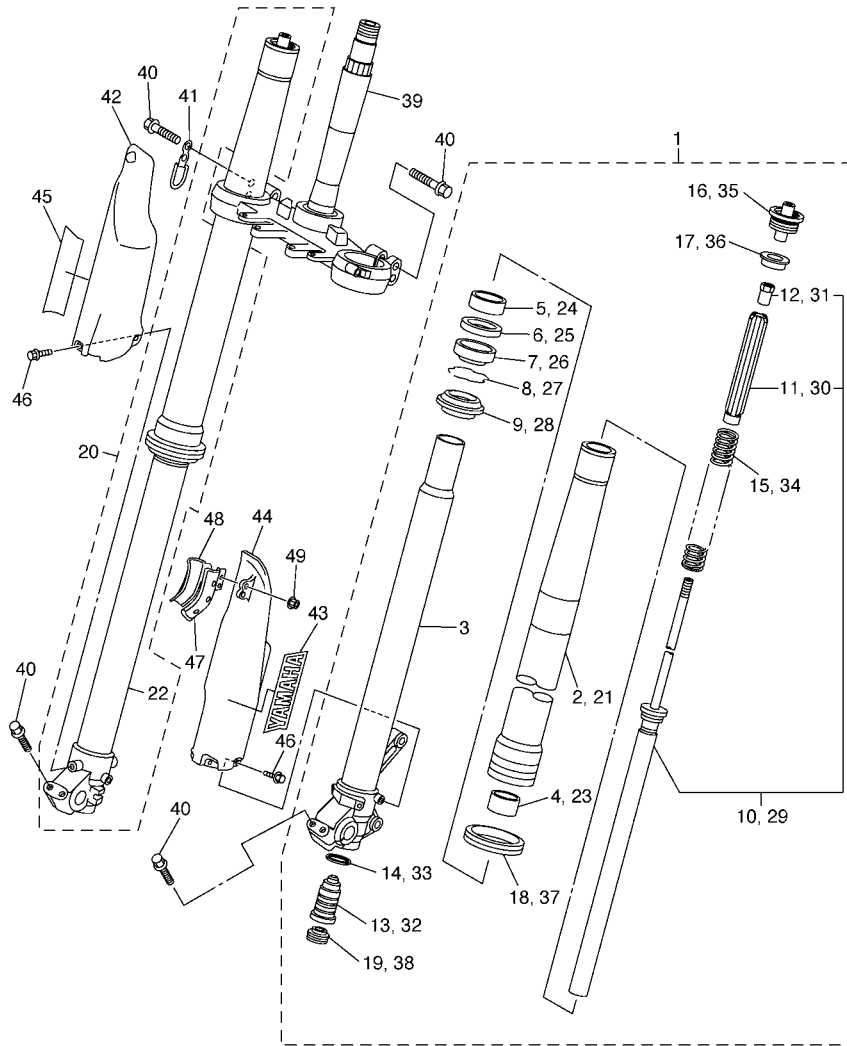

5TJB100-E270

FIG. 27 FRONT FORK

REF. NO.	PART NO.	DESCRIPTION	STJM				REMARKS
1	5TJ-23102-F0	FRONT FORK ASSY (L.H)	1				
2	5TJ-23136-C0	.TUBE, OUTER (RIGHT)	1				
3	5TJ-23120-C0	.INNER TUBE COMP.2	1				
4	5XE-23171-L0	.PISTON, FRONT FORK	1				
5	5XE-23125-L0	.METAL, SLIDE 1	1				
6	5XE-23146-L0	.WASHER, OIL SEAL	1				
7	1C3-23145-L0	.OIL SEAL	1				
8	5XE-23153-L0	.RING, SNAP	1				
9	5XE-23144-L0	.SEAL, DUST	1				
10	5UM-23170-E0	.CYLINDER COMP., FRONT FORK	1				
11	5XE-23142-L0	..SEAT, SPRING UPPER	1				
12	5XE-23393-L0	..NUT, SPECIAL	1				
13	5TJ-2316A-F0	.VALVE COMP.	1				
14	4SS-23158-L0	.GASKET	1				
15	5TJ-23141-L0	.SPRING,FRONT FORK(K=4.5N/MM)	1				
16	5XE-23111-L0	.BOLT, CAP	1				
17	5XE-23117-L0	.GUIDE, SPRING	1				
18	1C3-2314F-M0	.PROTECTOR GUIDE COMP, 1	1				
19	3JD-2312G-L0	.PLUG	1				
20	5TJ-23103-F0	FRONT FORK ASSY (R.H)	1				
21	5TJ-23136-C0	.TUBE, OUTER (RIGHT)	1				
22	5TJ-23110-C0	.INNER TUBE COMP.1	1				
23	5XE-23171-L0	.PISTON, FRONT FORK	1				
24	5XE-23125-L0	.METAL, SLIDE 1	1				
25	5XE-23146-L0	.WASHER, OIL SEAL	1				
26	1C3-23145-L0	.OIL SEAL	1				
27	5XE-23153-L0	.RING, SNAP	1				

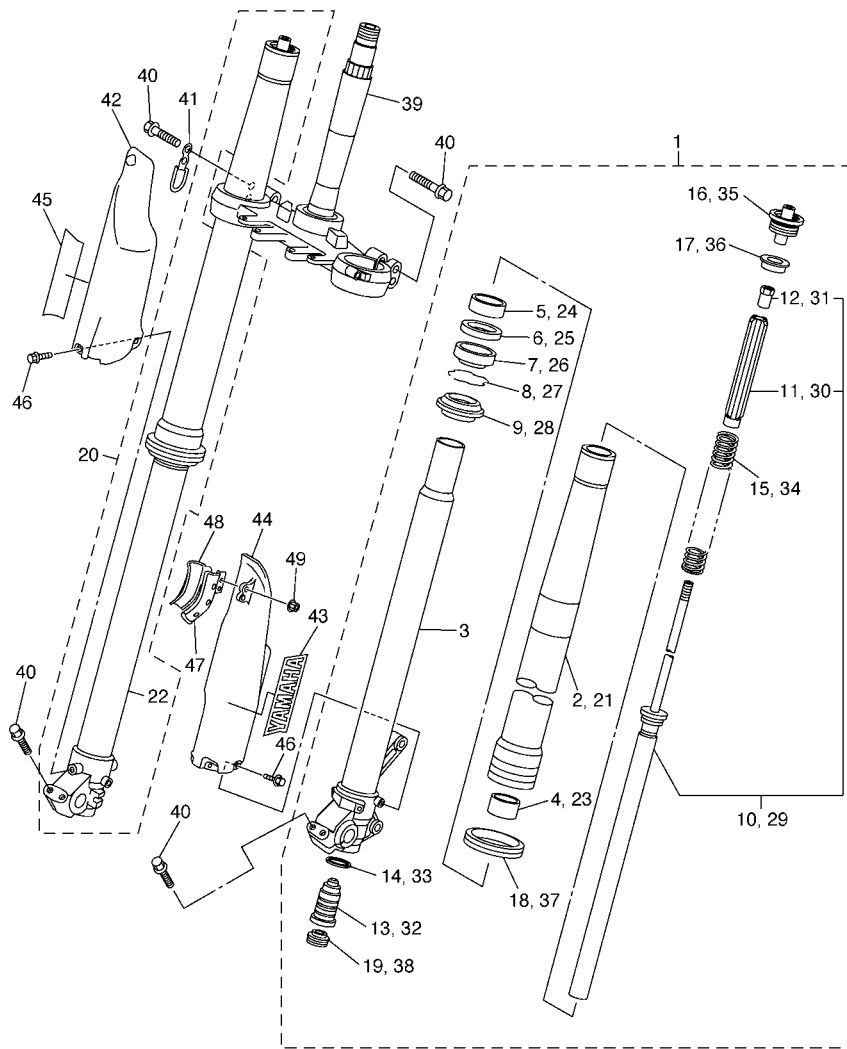
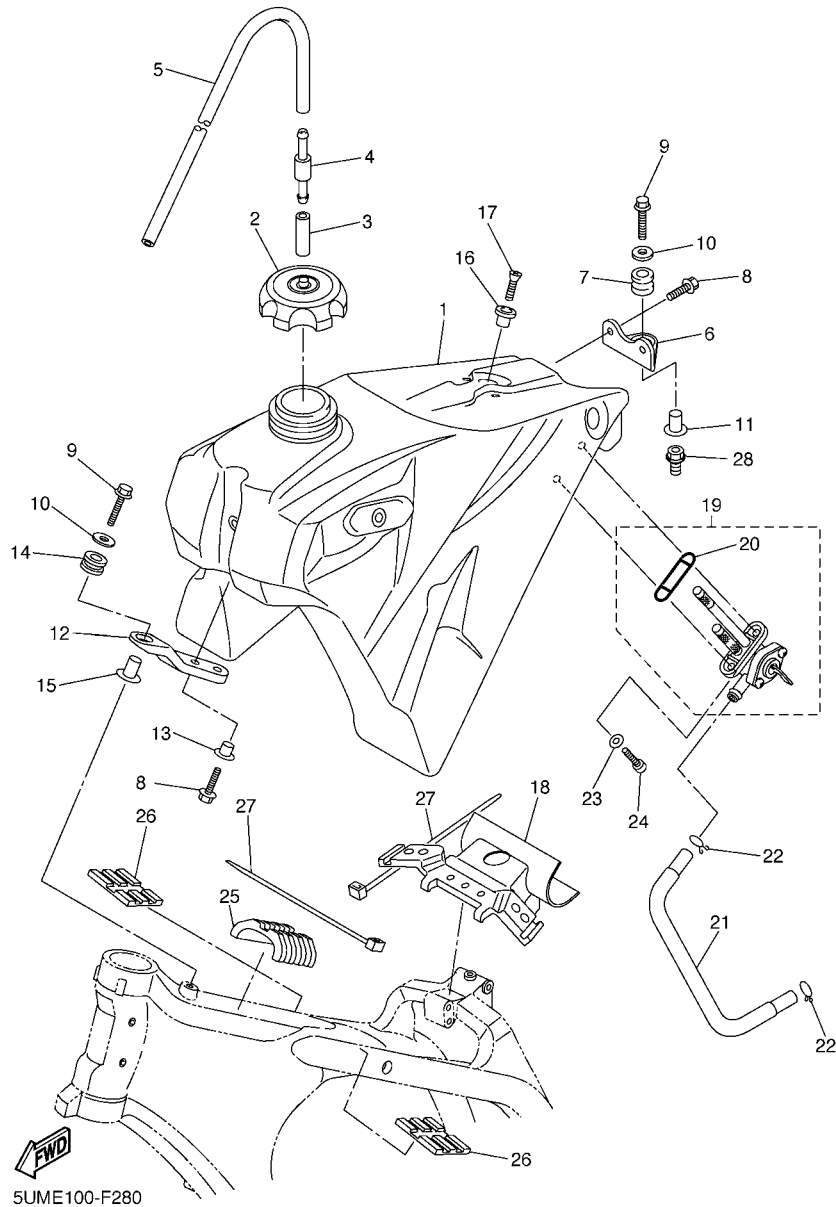

FIG. 27 FRONT FORK

REF. NO.	PART NO.	DESCRIPTION	STJM				REMARKS
28	5XE-23144-L0	.SEAL, DUST	1				
29	5UM-23170-E0	.CYLINDER COMP., FRONT FORK	1				
30	5XE-23142-L0	..SEAT, SPRING UPPER	1				
31	5XE-23393-L0	..NUT, SPECIAL	1				
32	5TJ-2316A-F0	.VALVE COMP.	1				
33	4SS-23158-L0	.GASKET	1				
34	5TJ-23141-L0	.SPRING, FRONT FORK (K=4.5N/MM)	1				
35	5XE-23111-L0	.BOLT, CAP	1				
36	5XE-23117-L0	.GUIDE, SPRING	1				
37	1C3-2314F-M0	.PROTECTOR GUIDE COMP., 1	1				
38	3JD-2312G-L0	.PLUG	1				
39	5TJ-23340-M0	UNDER BRACKET COMP.	1				
40	90105-08134	BOLT, FLANGE	8				
41	5TJ-23525-C0	GUIDE	1				
42	5TJ-2315J-C0	PROTECTOR 2	1				
43	4XL-2153A-10	EMBLEM, YAMAHA	1				
44	1C3-2315H-10	PROTECTOR 1	1				
45	4XL-2153A-10	EMBLEM, YAMAHA	1				
46	3SP-23356-L0	BOLT 2	6				
47	5XC-23466-L0	CLAMP	1				
48	5XC-23467-L0	CLAMP	1				
49	95702-06500	NUT, WITH WASHER	2				



5TJB100-E270



5UME100-F280

FIG. 28 FUEL TANK

REF. NO.	PART NO.	DESCRIPTION	QTY				REMARKS
1	5UM-24110-E1	FUEL TANK COMP.	1				
2	5NY-24610-00	CAP ASSY	1				
3	90445-09220	HOSE (L30)	1				
4	3XJ-24380-00	PIPE JOINT ASSY	1				
5	90445-09251	HOSE (L350)	1				
6	5XE-24144-00	HOLDER, DAMPER	1				
7	90480-18549	GROMMET	1				
8	90105-06107	BOLT, FLANGE	4				
9	90105-06111	BOLT, FLANGE	2				
10	90201-06570	WASHER, PLATE	2				
11	3JD-24186-00	WASHER, SPECIAL	1				
12	5XC-2419A-90	HOLDER	1				
13	90387-06090	COLLAR	2				
14	5XC-24339-90	GROMMET	1				
15	90387-06065	COLLAR	1				
16	4EW-2412F-00	BRACKET, SEAT	1				
17	98702-06025	SCREW, FLAT HEAD	1				
18	5UM-24181-E0	DAMPER, LOCATING 1	1				
19	5UM-24500-E0	FUEL COCK ASSY 1	1				
20	1P6-24512-00	.GASKET	1				
21	5TJ-24311-E0	PIPE, FUEL 1	1				
22	90467-100A1	CLIP	2				
23	90202-05193	WASHER, PLATE	2				
24	90149-06108	SCREW	2				
25	5XC-24182-90	DAMPER, LOCATING 2	1				
26	5XC-24183-90	DAMPER, LOCATING 3	2				
27	90465-13275	CLAMP	3				

FIG. 28 FUEL TANK

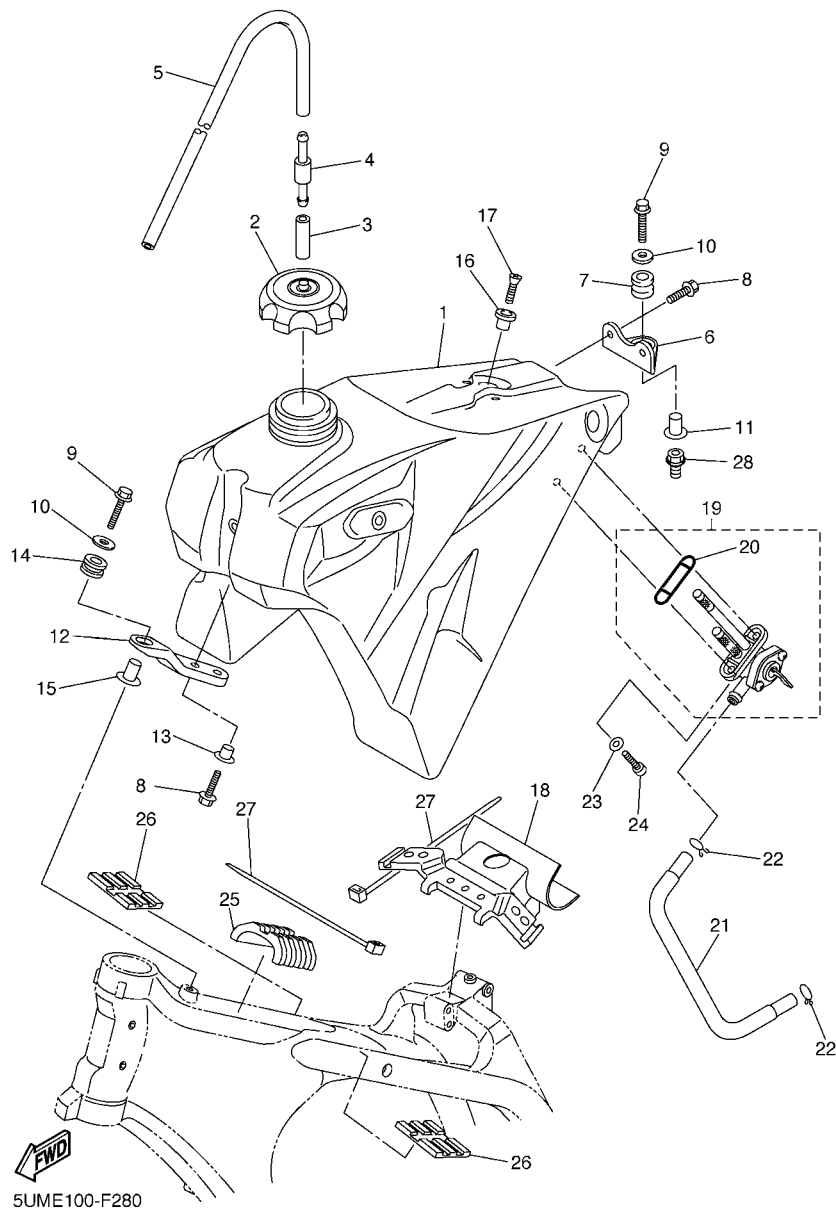

REF. NO.	PART NO.	DESCRIPTION	STJM				REMARKS
28	1C3-21244-10	NUT	1				

FIG. 29 SEAT

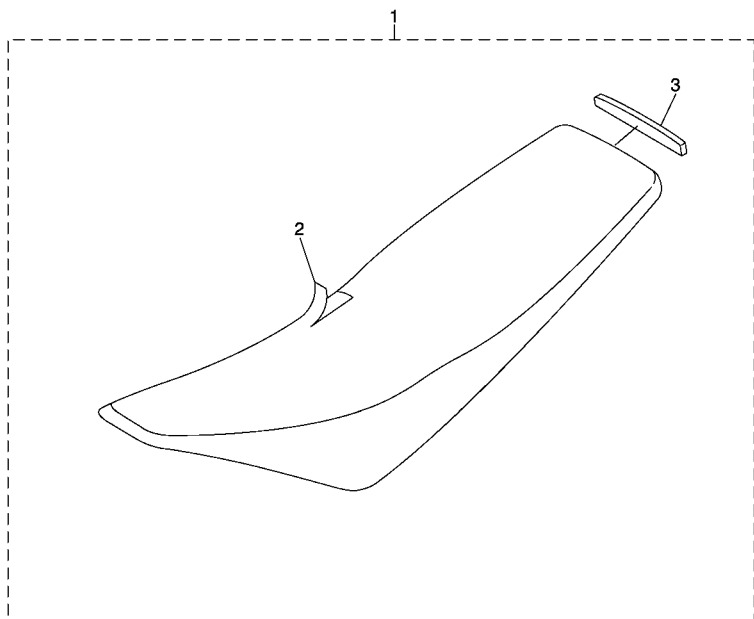

REF. NO.	PART NO.	DESCRIPTION	STJM				REMARKS
1	5UM-24710-E0	SINGLE SEAT ASSY	1				
2	5UM-2470F-E0	.SEAT COVER COMP.	1				
3	5UM-24723-E0	.DAMPER, SEAT	1				

5TJE100-F290

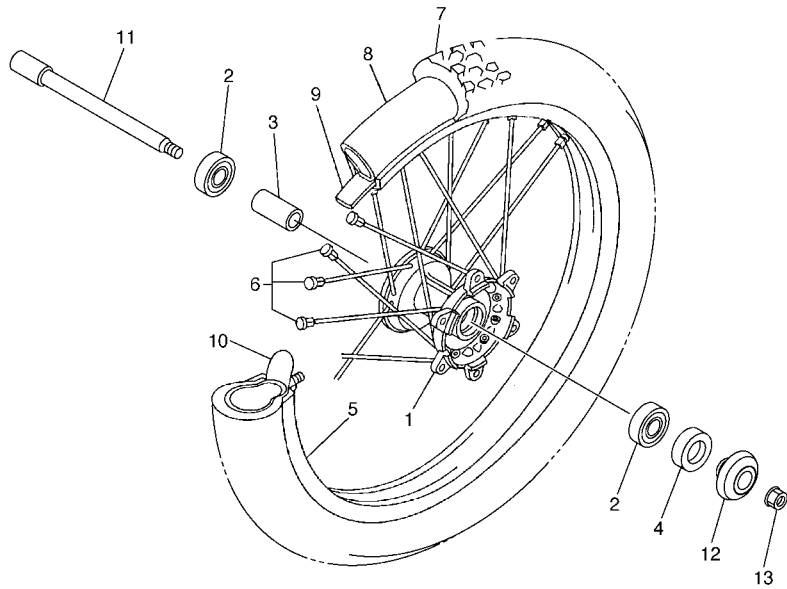

FIG. 30 FRONT WHEEL

REF. NO.	PART NO.	DESCRIPTION	STJM				REMARKS
1	5NG-25111-50	HUB, FRONT	1				
2	93306-90409	BEARING	2				
3	5NY-25117-00	SPACER, BEARING	1				
4	93102-26468	OIL SEAL	1				
5	94416-21018	RIM (1.60-21)	1				
6	5NY-25104-00	SPOKE SET, FRONT	1				
7	L.M.	TIRE (80/100-21 M/C 54R D908F)	1				
8	L.M.	TUBE (80/100-21 M/C TR4)	1				
9	94309-21161	BAND, RIM (1.60-21)	1				
10	5SF-25394-00	SPACER, BEAD	1				
11	1C3-25181-10	AXLE, WHEEL	1				
12	5TJ-2510C-80	COLLAR ASSY.	1				
13	90179-16011	NUT	1				



5TJB100-E300

FIG. 31 FRONT BRAKE CALIPER

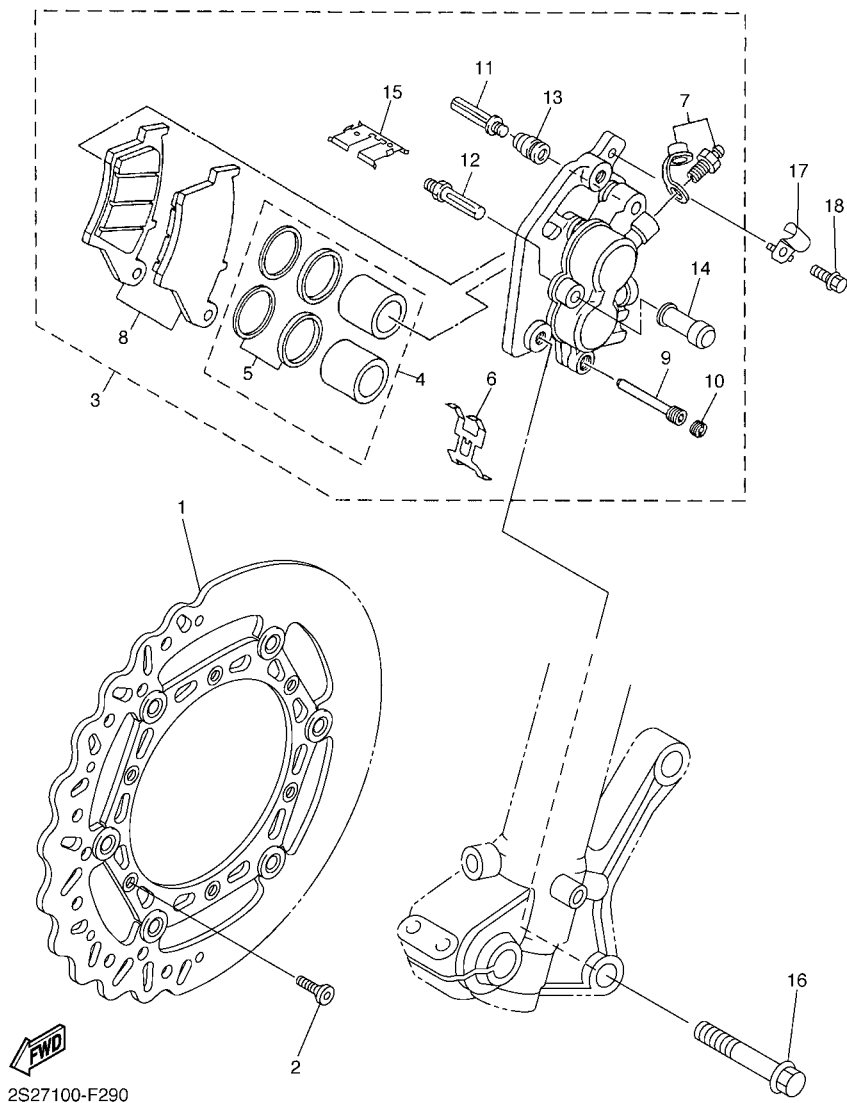

REF. NO.	PART NO.	DESCRIPTION	STJM				REMARKS
1	2S2-2581T-70	DISK BRAKE ASSY	1				
2	90151-06051	SCREW, COUNTERSUNK	6				
3	1C3-2580T-00	CALIPER ASSY (LEFT)	1				
4	5UN-W0057-00	.PISTON ASSY, CALIPER	1				
5	3JD-W0047-00	..CALIPER SEAL KIT	1				
6	5DH-25919-00	.SUPPORT, PAD	1				
7	1UY-W0048-50	.BLEED SCREW KIT	1				
8	5MV-W0045-01	.BRAKE PAD KIT	1				
9	5DH-25933-00	.PIN, PAD	1				
10	5DH-25916-00	.PLUG	1				
11	3SP-25926-51	.BOLT	1				
12	3SP-25914-51	.PIN, SLIDE	1				
13	3JD-25917-00	.BOOT, CALIPER	1				
14	1UY-25937-51	.BOOT 2	1				
15	5DH-25849-00	.RETAINER, CALIPER	1				
16	90105-08137	BOLT, FLANGE	2				
17	1C3-25875-50	HOLDER, BRAKE HOSE 1	1				
18	90105-06105	BOLT, FLANGE	1				

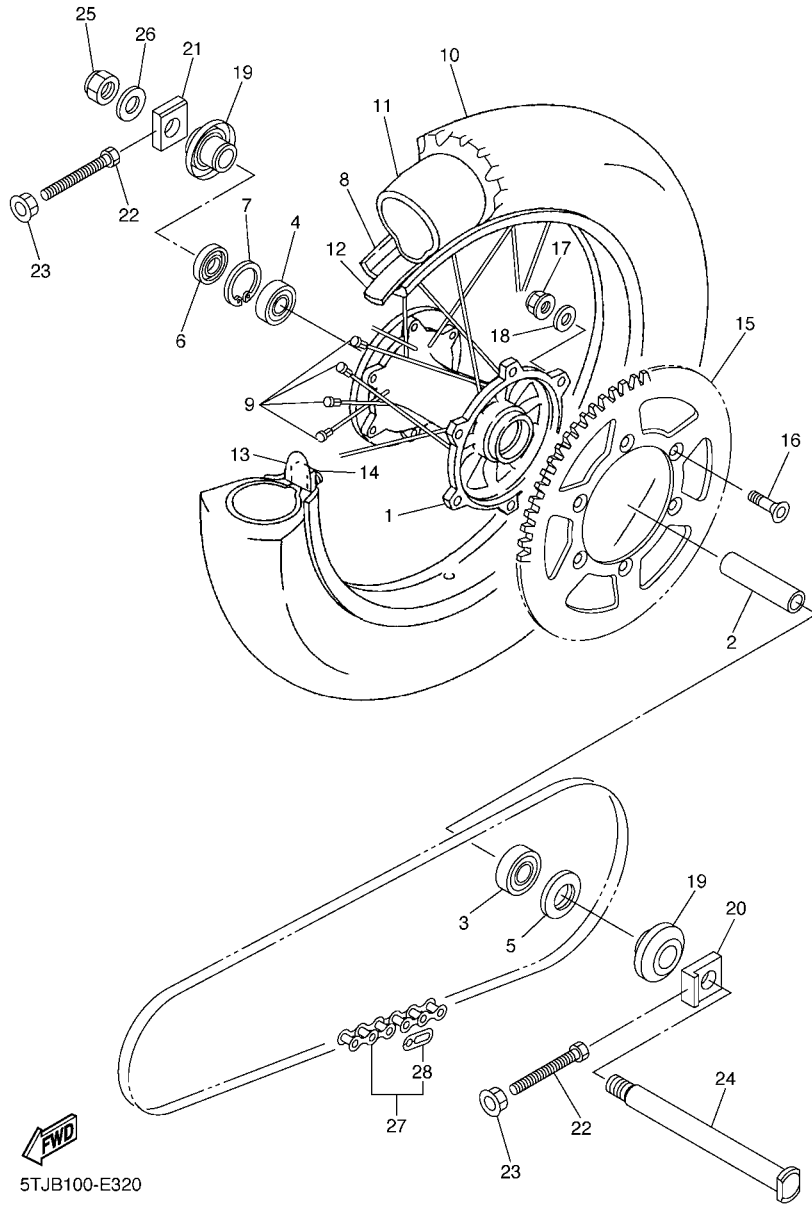

5TJB100-E320

FIG. 32 REAR WHEEL

REF. NO.	PART NO.	DESCRIPTION	STJM				REMARKS
1	5ET-25311-00	HUB, REAR	1				
2	5ET-25317-00	SPACER, BEARING	1				
3	93306-27212	BEARING	1				
4	93306-07202	BEARING	1				
5	93106-30001	OIL SEAL	1				
6	93106-30045	OIL SEAL	1				
7	99009-45500	CIRCLIP	1				
8	94421-18008	RIM (2.15-18)	1				
9	5GS-25304-00	SPOKE SET, REAR	1				
10	L.M.	TIRE (110/100-18 M/C 69R D908)	1				
11	L.M.	TUBE (110/80-18)	1				
12	94309-18146	BAND, RIM (2.15-18)	1				DUNLOP
13	3JE-25394-00	SPACER, BEAD	2				
14	4XM-25364-00	DAMPER	2				
15	5TJ-25450-80	SPROCKET, DRIVEN (50T)	1				STD FOR ZAF
	1C3-25448-00	SPROCKET, DRIVEN (48T)	1				AP FOR OCE
	1C3-25449-00	SPROCKET, DRIVEN (49T)	1				AP FOR OCE
	1C3-25451-00	SPROCKET, DRIVEN (51T)	1				AP FOR OCE
	1C3-25452-00	SPROCKET, DRIVEN (52T)	1				AP FOR OCE
	5GS-25448-50	SPROCKET, DRIVEN (48T)	1				AP FOR ZAF
	5TJ-25452-80	SPROCKET, DRIVEN (52T)	1				AP FOR ZAF
16	90109-08078	BOLT	6				
17	90185-08008	NUT, SELF-LOCKING	6				
18	90201-08048	WASHER, PLATE	6				

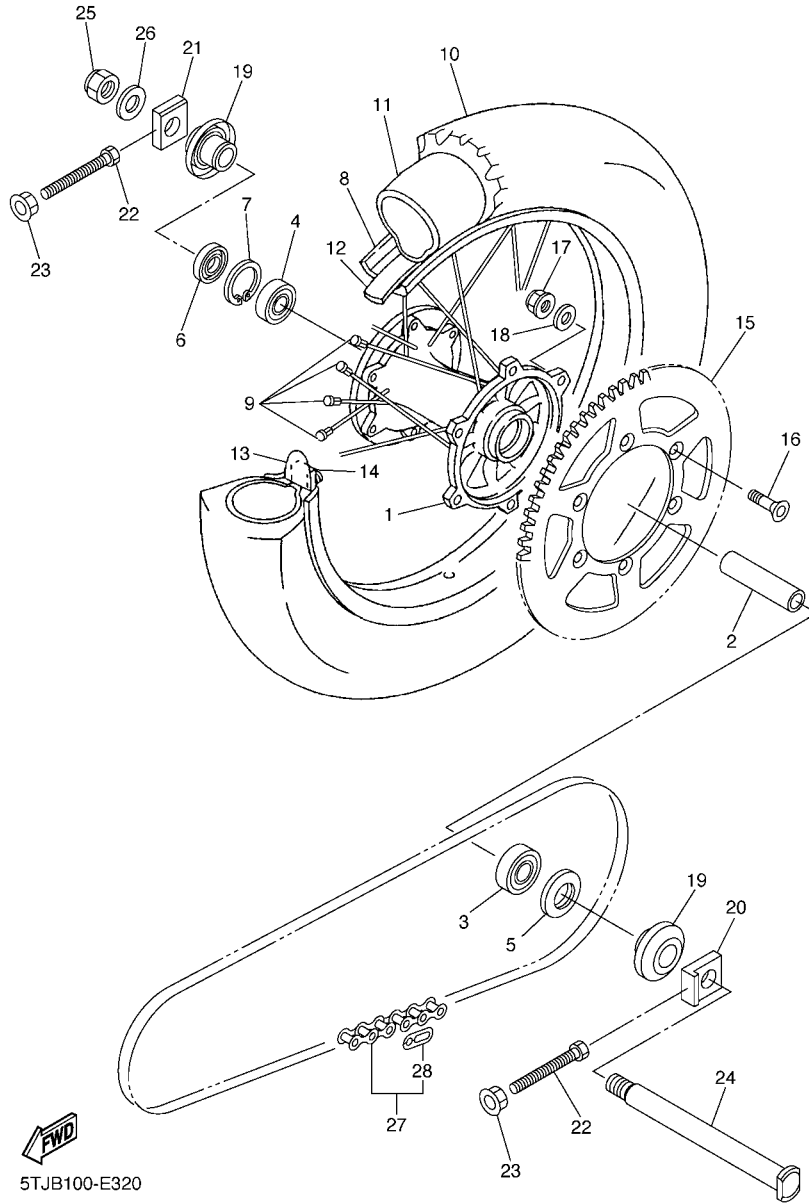

5TJB100-E320

FIG. 32 REAR WHEEL

REF. NO.	PART NO.	DESCRIPTION	5TJM			REMARKS
19	5TJ-2530S-80	COLLAR ASSY	2			
20	1C3-25388-50	PULLER, CHAIN 1	1			
21	1C3-25389-00	PULLER, CHAIN 2	1			
22	90101-08006	BOLT	2			
23	90179-08019	NUT	2			
24	1C3-25381-90	AXLE, WHEEL	1			
25	90185-20002	NUT, SELF-LOCKING	1			
26	90201-20020	WASHER, PLATE	1			
27	9Y58A-76113	CHAIN (DID 520VM-114LL)	1			
28	94681-76021	.JOINT, CHAIN (DID 520VM-ZJ)	1			

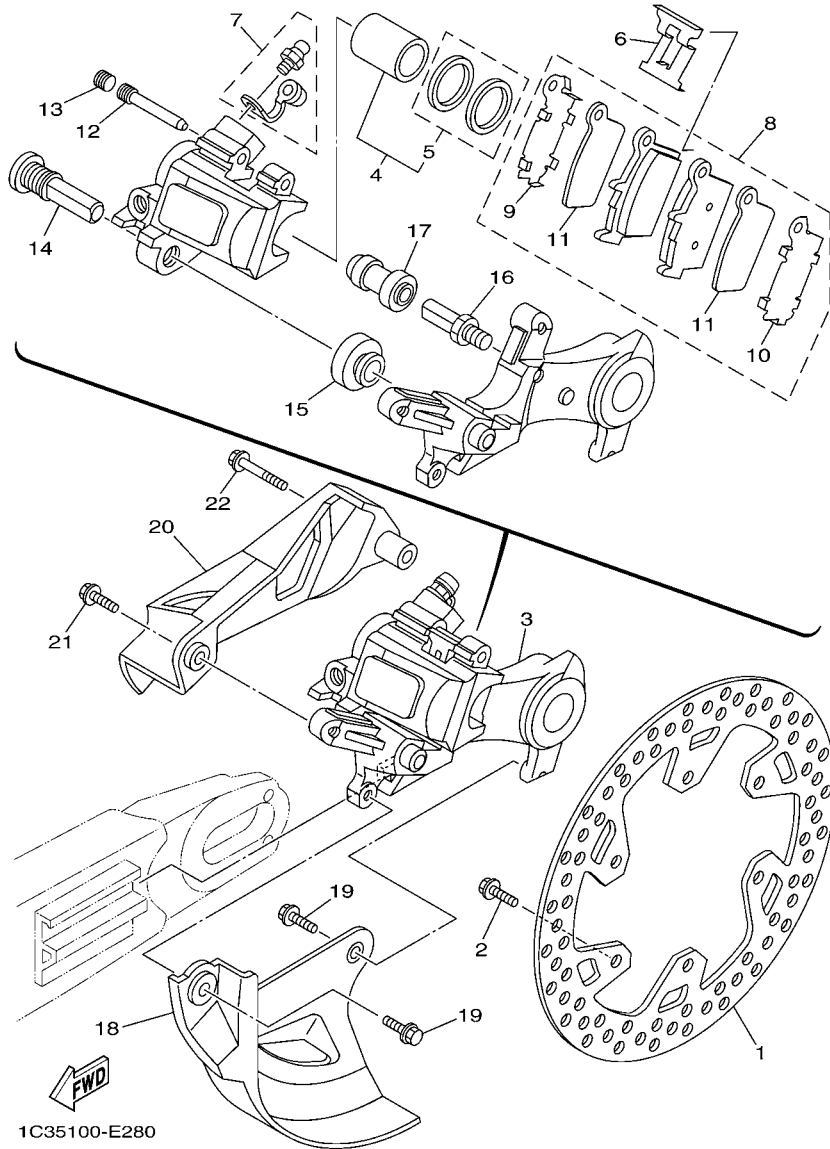
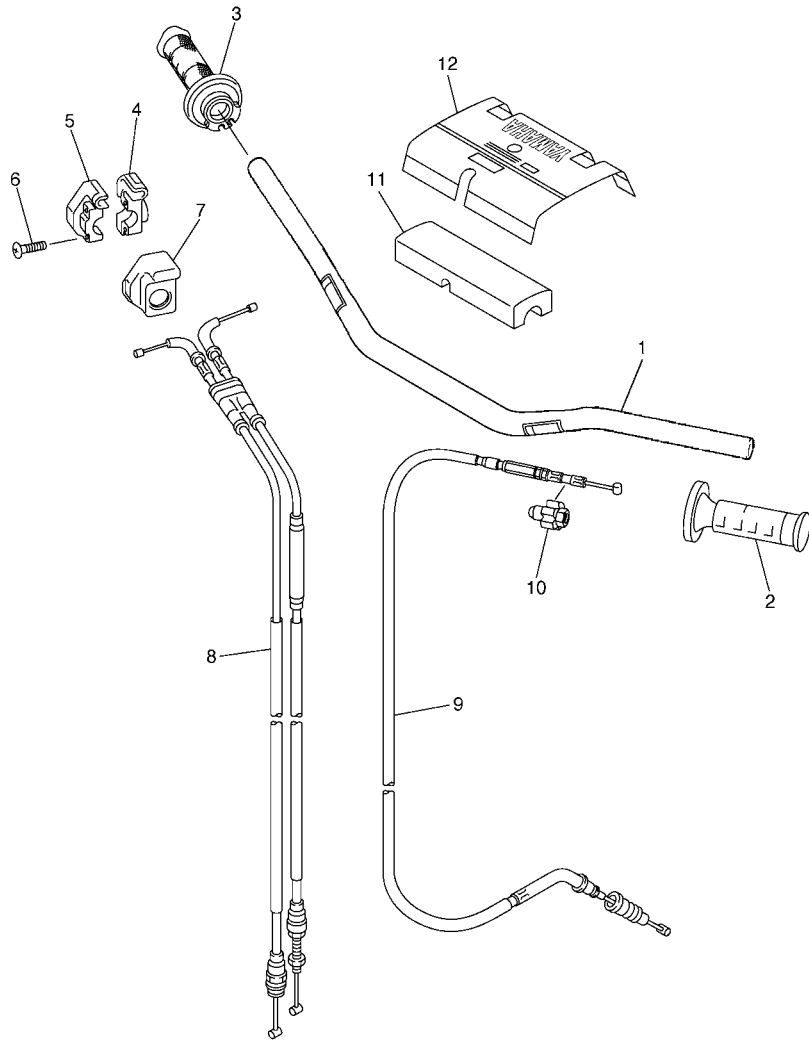

FIG. 33 REAR BRAKE CALIPER

REF. NO.	PART NO.	DESCRIPTION	STJM				REMARKS
1	2S2-2582W-70	DISK, REAR BRAKE 2	1				
2	90105-06108	BOLT, FLANGE	6				
3	1C3-2580W-71	CALIPER ASSY, REAR 2	1				
4	5UN-W0057-50	.PISTON ASSY, CALIPER	1				
5	5UN-W0047-50	..CALIPER SEAL KIT	1				
6	5DH-25919-50	..SUPPORT, PAD	1				
7	1UY-W0048-50	.BLEED SCREW KIT	1				
8	1C3-W0046-B0	.BRAKE PAD KIT 2	1				
9	5UN-25828-60	..SHIM, CALIPER	1				
10	5UN-25827-60	..SHIM, CALIPER	1				
11	5UN-22898-60	..INSULATOR, HEAT	2				
12	8CR-25924-00	.PIN, PAD	1				
13	5DH-25916-00	.PLUG	1				
14	5DH-25914-50	.PIN, SLIDE	1				
15	3JD-25917-00	.BOOT, CALIPER	1				
16	5UN-25914-00	.PIN, SLIDE	1				
17	1UY-25937-51	.BOOT 2	1				
18	1C3-25718-50	PROTECTOR, DISK BRAKE	1				
19	90105-06110	BOLT, FLANGE	2				
20	1C3-27491-50	PROTECTOR	1				
21	90105-06107	BOLT, FLANGE	1				
22	90105-06111	BOLT, FLANGE	1				

FIG. 34 STEERING HANDLE & CABLE



REF. NO.	PART NO.	DESCRIPTION	STJM				REMARKS
1	5XC-26111-L0	HANDLEBAR	1				
2	4GY-26241-00	GRIP	1				
3	5TJ-26240-C0	GRIP ASSY	1				
4	5BE-26281-00	CAP, GRIP UPPER	1				
5	5BE-26282-00	CAP, GRIP LOWER	1				
6	98502-05020	SCREW, PAN HEAD	2				
7	5SF-26287-10	COVER, CAP GRIP	1				
8	5UM-26302-E0	THROTTLE CABLE ASSY	1				
9	5TJ-26335-E0	CABLE, CLUTCH	1				
10	1C3-26342-50	BOOT, CABLE	1				
11	5XC-26124-90	PROTECTOR, HANDLEBAR	1				
12	5XC-26143-L0	COVER, HANDLEBAR UPPER 1	1				

5TJE100-F340

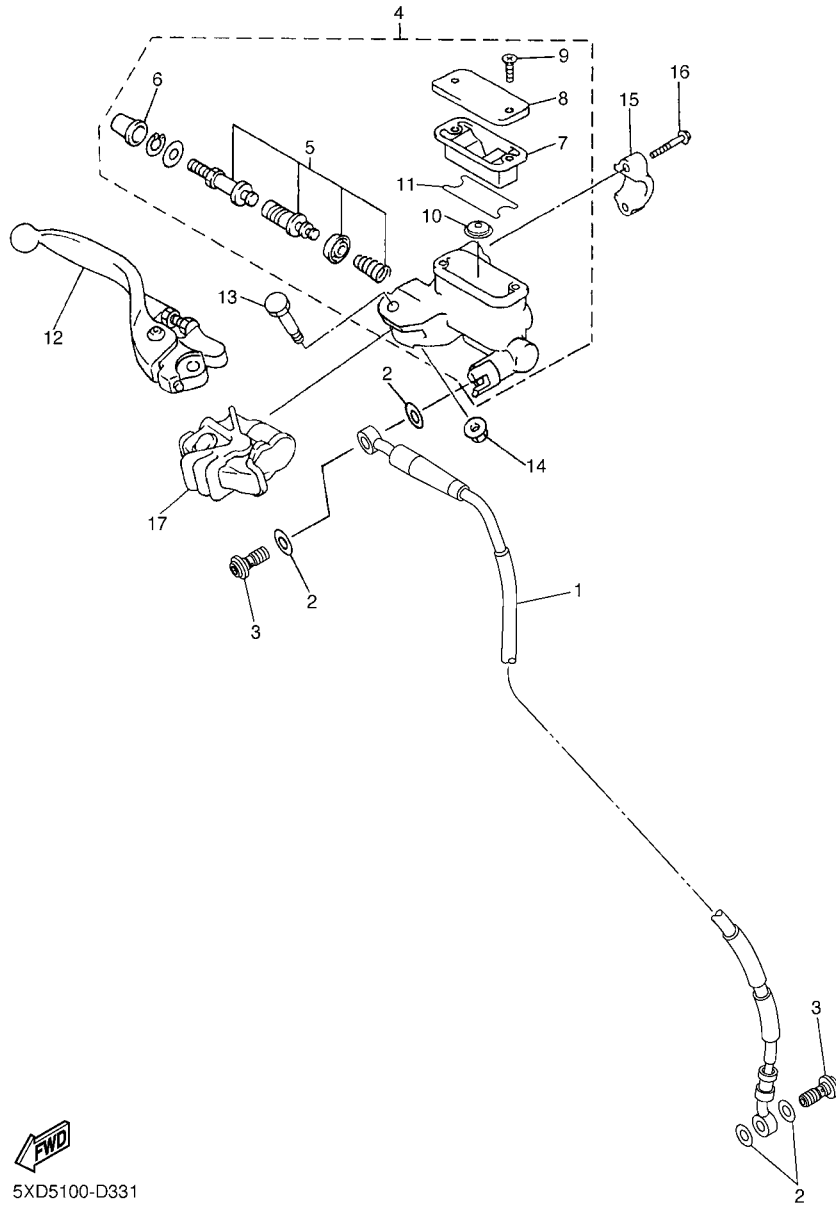

FIG. 35 FRONT MASTER CYLINDER

REF. NO.	PART NO.	DESCRIPTION	STJM				REMARKS
1	5TJ-25872-80	HOSE, BRAKE 1	1				
2	90430-10005	GASKET	4				
3	90401-10172	BOLT, UNION	2				
4	5XE-W2587-10	MASTER CYLINDER SUB ASSY	1				
5	5NY-W0041-00	.CYLINDER KIT, MASTER	1				
6	5NY-25868-00	.BOOT, MASTER CYLINDER	1				
7	5XE-25854-00	.DIAPHRAGM, RESERVOIR	1				
8	5MV-25852-01	.CAP, RESERVOIR	1				
9	98706-04012	.SCREW, FLAT HEAD	2				
10	5CG-25715-00	.SEPARATOR ASSY	1				
11	5XE-25853-00	.FLOAT, RESERVOIR	1				
12	1C3-83922-50	LEVER 2	1				
13	5MV-2589F-00	BOLT, LEVER	1				
14	95701-06500	NUT, WITH WASHER	1				
15	5MV-25867-00	BRACKET, MASTER CYLINDER	1				
16	5MV-25833-00	BOLT, FITTING	2				
17	5NY-26372-00	COVER, HANDLE LEVER 1	1				



5XD5100-D331

FIG. 36 STAND & FOOTREST

REF. NO.	PART NO.	DESCRIPTION	STJM				REMARKS
1	2S2-27200-10	PEDAL, BRAKE	1				
2	1C3-27217-10	BOLT	1				
3	93210-11073	O-RING	2				
4	91402-20012	PIN, COTTER	1				
5	90506-16007	SPRING, TENSION	1				
6	90240-08120	PIN, CLEVIS	1				
7	90201-08044	WASHER, PLATE	1				
8	90468-16001	CLIP	1				
9	5XC-27411-M0	FOOTREST 1	1				
10	5XC-27421-M0	FOOTREST 2	1				
11	90240-10004	PIN, CLEVIS	2				
12	91402-25015	PIN, COTTER	2				
13	90508-28015	SPRING, TORSION	1				
14	90508-28018	SPRING, TORSION	1				
15	90201-10032	WASHER, PLATE	2				
16	5UM-27311-E0	STAND, SIDE	1				
17	90506-30005	SPRING, TENSION	1				
18	90445-217G3	HOSE (L70)	1				
19	90109-10026	BOLT	1				
20	90201-10045	WASHER, PLATE	1				
21	90387-1003G	COLLAR	1				
22	5UM-27315-E0	LINK, SIDE STAND	1				
23	90185-10018	NUT, SELF-LOCKING	1				

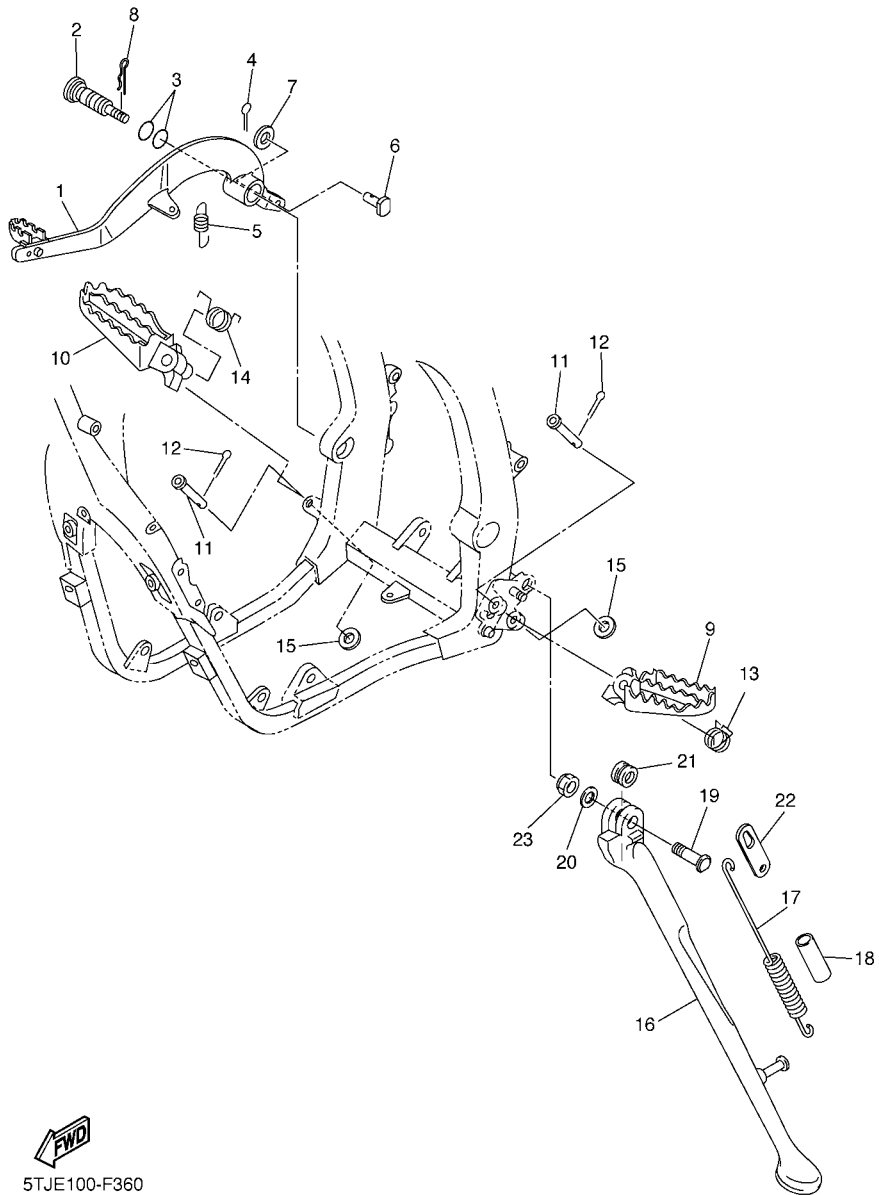

FWD
5TJE100-F360

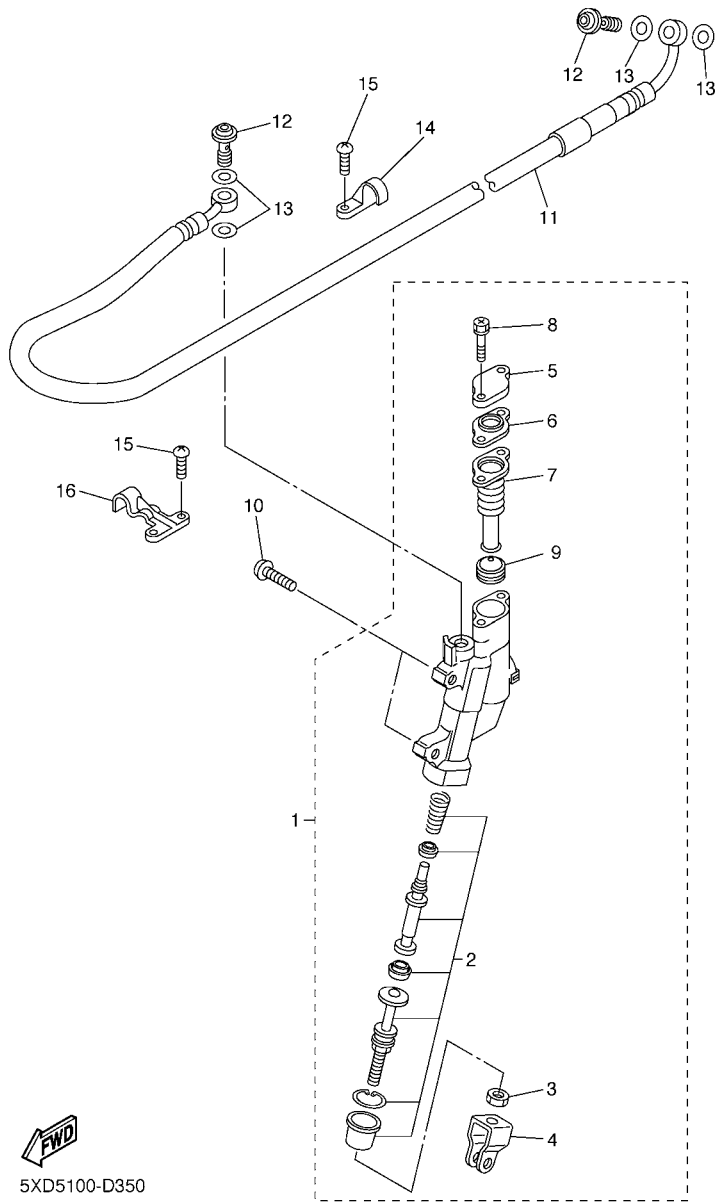

5XD5100-D350

FIG. 37 REAR MASTER CYLINDER

REF. NO.	PART NO.	DESCRIPTION	STJM				REMARKS
1	1C3-2583V-00	RR. MASTER CYLINDER ASSY.	1				
2	5UN-W0042-50	.CYLINDER KIT, MASTER	1				
3	5UN-27218-00	.NUT	1				
4	5UN-27222-00	.JOINT	1				
5	5UN-25852-50	.CAP, RESERVOIR	1				
6	5UN-2585B-00	.PLATE, DIAPHRAGM	1				
7	5UN-25854-00	.DIAPHRAGM, RESERVOIR	1				
8	5UN-27217-00	.BOLT	2				
9	5CG-25715-00	.SEPARATOR ASSY	1				
10	90111-06059	BOLT,HEX. SOCKET BUTTON	2				
11	5XC-25873-L0	HOSE, BRAKE 2	1				
12	90401-10172	BOLT, UNION	2				
13	90430-10005	GASKET	4				
14	1C3-25886-50	HOLDER, BRAKE HOSE	1				
15	98502-05010	SCREW, PAN HEAD	4				
16	1C3-25876-50	HOLDER, BRAKE HOSE 2	1				

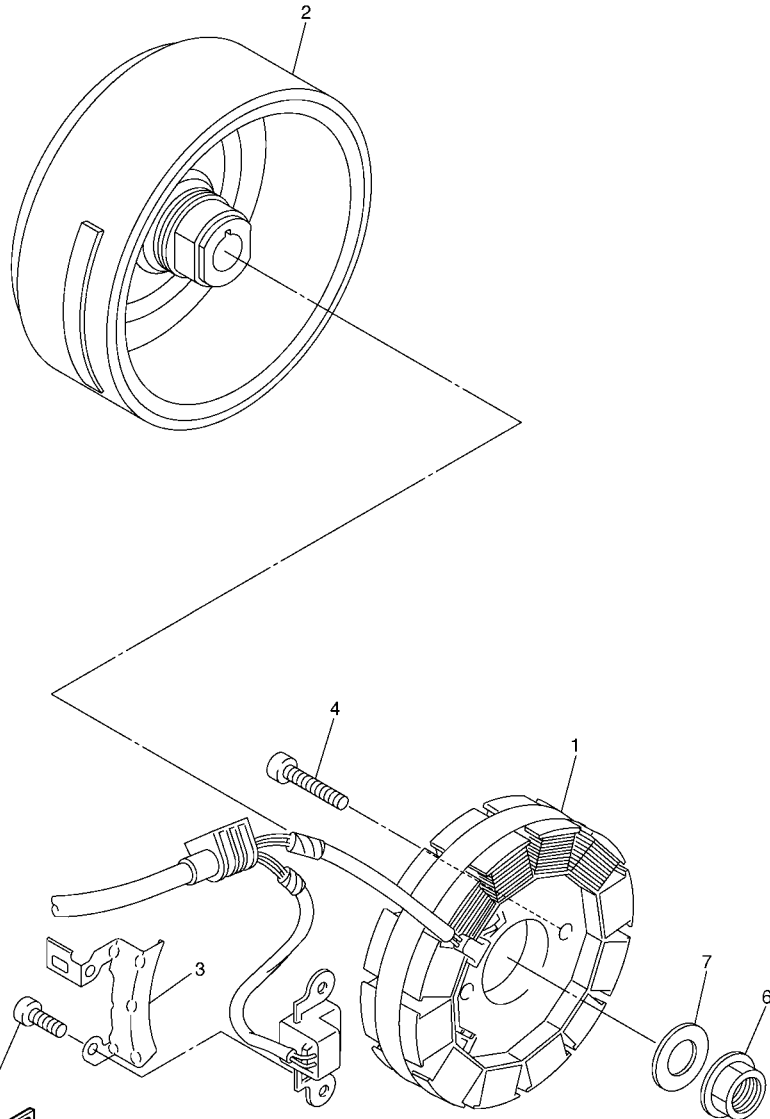

5TJE100-F380

FIG. 38 GENERATOR

REF. NO.	PART NO.	DESCRIPTION	5TJM				REMARKS
1	5TJ-81410-50	STATOR ASSY	1				
2	5TJ-81450-30	ROTOR ASSY	1				
3	5TJ-81528-00	CLAMP 1	1				
4	90149-05024	SCREW	2				
5	90110-06248	BOLT, HEXAGON SOCKET HEAD	2				
6	90179-12657	NUT	1				
7	90201-12020	WASHER, PLATE	1				

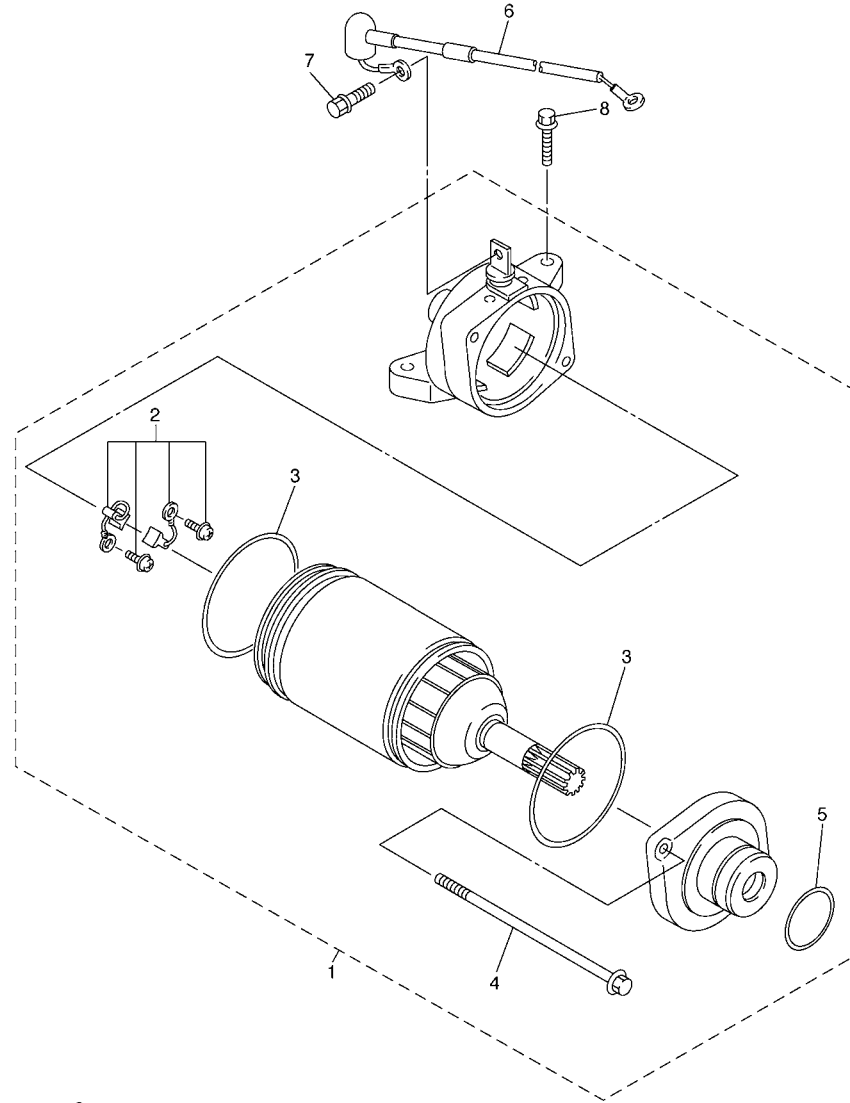

FIG. 39 STARTING MOTOR

REF. NO.	PART NO.	DESCRIPTION	5TJM				REMARKS
1	5TJ-81890-30	MOTOR ASSY	1				
2	5TJ-81801-00	.BRUSH SET	1				
3	93210-44678	.O-RING	2				
4	50W-81846-M1	.SCREW	2				
5	93210-25711	.O-RING	1				
6	5TJ-8183G-30	CORD COMP.	1				
7	5TJ-81828-01	BOLT 2	1				
8	95022-06025	BOLT, FLANGE	2				



5TJE100-F390

FIG. 40 METER

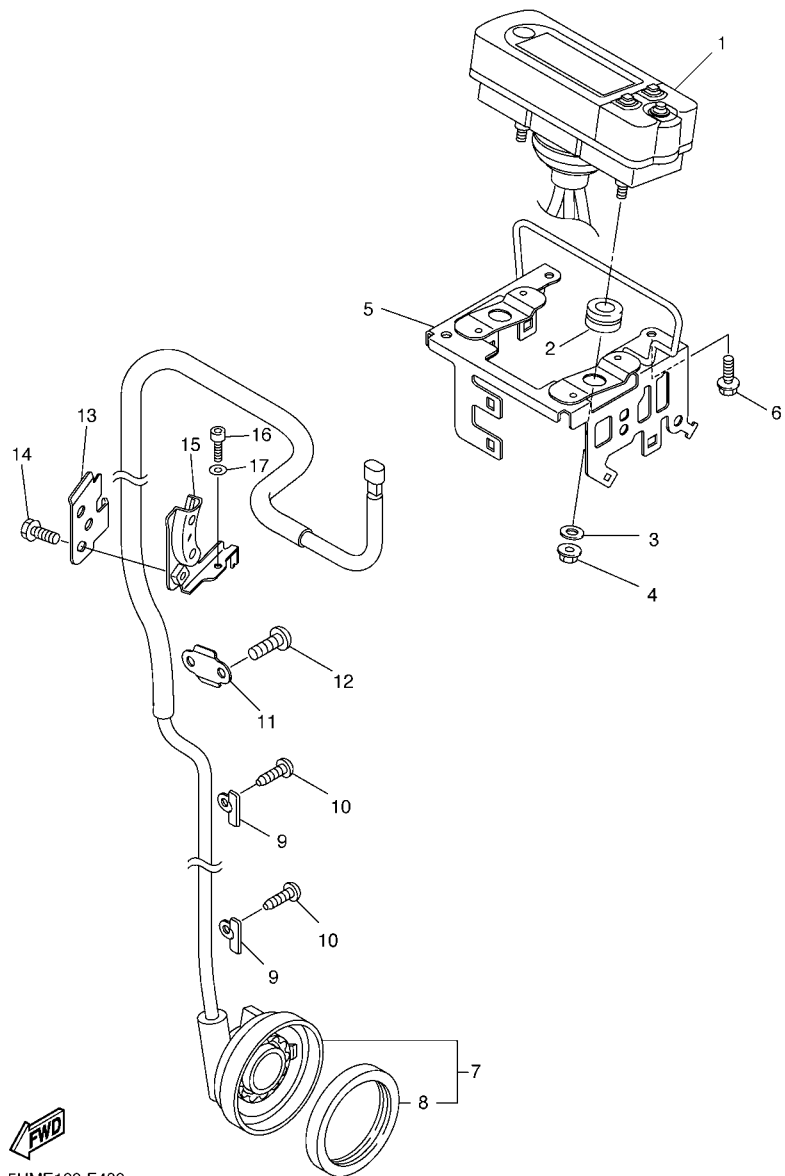

5UME100-F400

REF. NO.	PART NO.	DESCRIPTION	QTY	REMARKS
1	5TJ-83500-F0	SPEEDOMETER ASSY (KM/H)	1	
2	90480-14012	GROMMET	2	
3	90201-05021	WASHER, PLATE	2	
4	95702-05500	NUT, WITH WASHER	2	
5	5UM-83519-E0	BRACKET, METER	1	
6	90105-06110	BOLT, FLANGE	2	
7	5TJ-83755-C0	SENSOR, SPEED	1	
8	93105-47007	.OIL SEAL	1	
9	5TJ-8375F-C0	PLATE 2	2	
10	97702-40010	SCREW, TAPPING	2	
11	5TJ-8375E-C0	PLATE 1	1	
12	92012-05008	BOLT, BUTTON HEAD	2	
13	5UM-83595-E0	CLAMP	1	
14	90105-06105	BOLT, FLANGE	1	
15	5UM-23591-E0	BRACKET 1	1	
16	92012-06012	BOLT, BUTTON HEAD	1	
17	92902-06600	WASHER, PLATE	1	

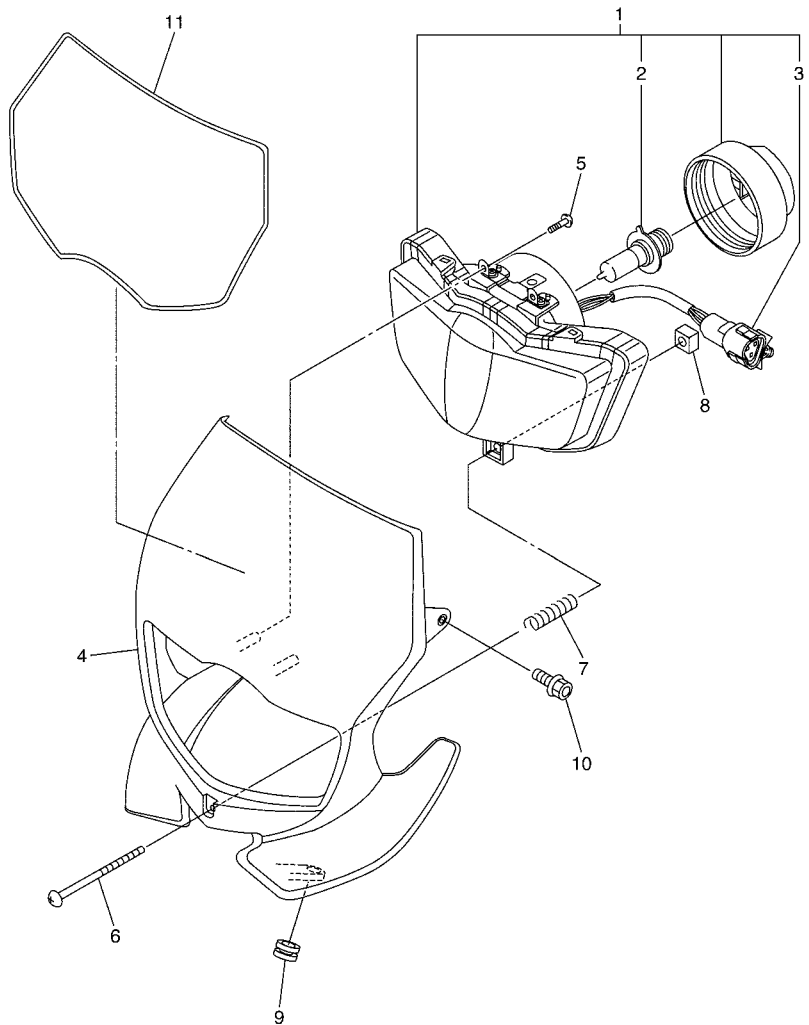

FWD
5TJJ100-G410

FIG. 41 HEADLIGHT

REF. NO.	PART NO.	DESCRIPTION	5TJM				REMARKS
1	5UM-84310-E1	HEADLIGHT UNIT ASSY	1				
2	5VM-84314-00	.BULB, HEADLIGHT(12V-35/36.5W)	1				HALOGEN
3	5UM-84340-E1	.SOCKET CORD ASSY 1	1				
4	5UM-84330-E0	BODY ASSY	1				
5	97702-50516	SCREW, TAPPING	2				
6	90157-04005	SCREW, PAN HEAD	1				
7	90501-120A3	SPRING, COMPRESSION	1				
8	5BF-84334-00	NUT, ADJUSTING	1				
9	90480-12020	GROMMET	2				
10	90105-06064	BOLT, FLANGE	2				
11	5TJ-2339E-00	GRAPHIC 1	1				

FIG. 42 TAILLIGHT

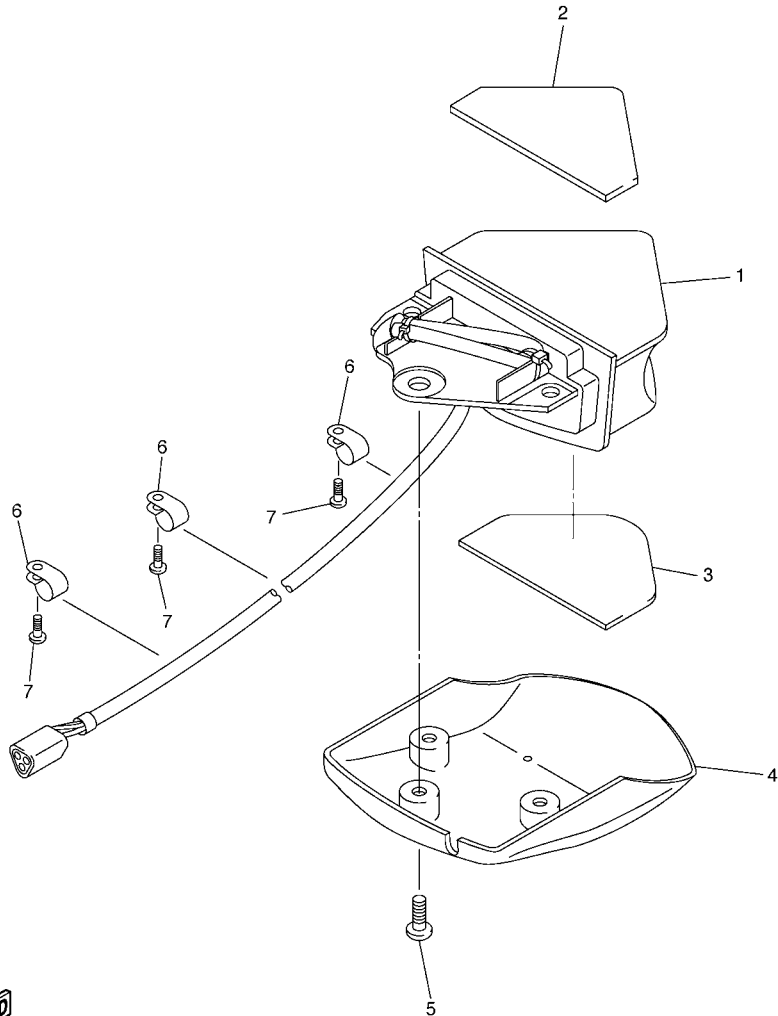

REF. NO.	PART NO.	DESCRIPTION	STUM				REMARKS
1	5UM-84710-E0	TAILLIGHT UNIT ASSY	1				
2	5UM-84736-E0	DAMPER, TAIL 1	1				
3	5UM-84737-E0	DAMPER, TAIL 2	1				
4	5UM-84716-E0	COVER, TAILLIGHT	1				
5	97702-50016	SCREW, TAPPING	3				
6	90464-11M18	CLAMP	3				
7	97702-40010	SCREW, TAPPING	3				



5UME100-F420

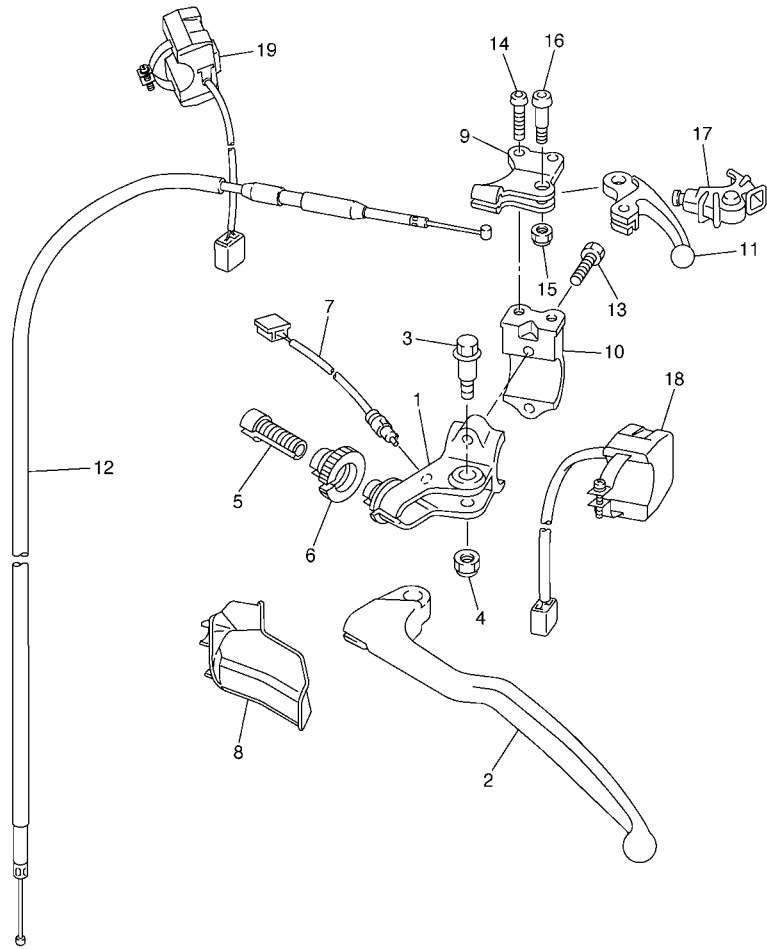

FIG. 43 HANDLE SWITCH & LEVER

REF. NO.	PART NO.	DESCRIPTION	STJM				REMARKS
1	5TJ-82911-80	HOLDER, LEVER 1	1				
2	5TJ-83912-80	LEVER 1	1				
3	90109-06034	BOLT	1				
4	5LP-84126-10	NUT, LENS FITTING	1				
5	5HD-26337-00	BOLT, ADJUSTING	1				
6	5HD-83951-00	BOLT, CABLE ADJUSTING	1				
7	5TJ-82917-02	SWITCH	1				
8	5TJ-26372-80	COVER, HANDLE LEVER 1	1				
9	5XD-82946-00	HOLDER, STARTER LEVER	1				
10	5XD-82913-00	HOLDER, LEVER LOWER 1	1				
11	5TA-83941-00	LEVER, STARTER	1				
12	5UM-26334-E0	CABLE, STARTER 2	1				
13	97002-05016	BOLT	2				
14	92012-05012	BOLT, BUTTON HEAD	2				
15	95602-05100	NUT, U	1				
16	90149-05162	SCREW	1				
17	5TA-26339-00	BOOT	1				
18	5UM-83976-E1	SWITCH, ENGINE STOP	1				
19	5UM-83976-F1	SWITCH, HANDLE 1	1				



5UME100-F430

FIG. 44 ELECTRICAL 1

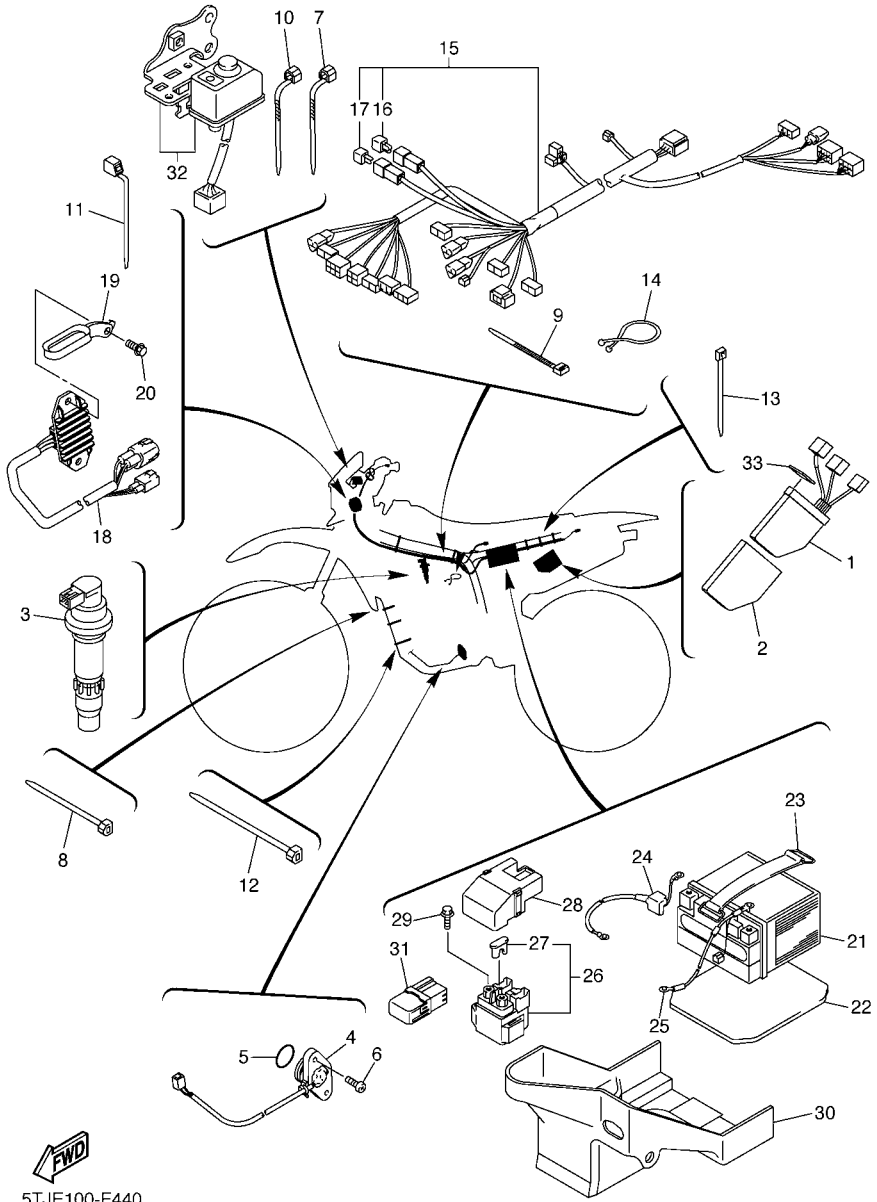
REF. NO.	PART NO.	DESCRIPTION	STJM				REMARKS
1	5TJ-85540-F0	C.D.I. UNIT ASSY	1				
2	5UM-85546-E0	BAND	1				
3	5TA-82310-10	IGNITION COIL ASSY	1				
4	5TJ-82540-01	NEUTRAL SWITCH ASSY	1				
5	93210-21001	O-RING	1				
6	90154-05022	SCREW, BINDING	2				
7	90464-13077	CLAMP	2				
8	90464-15152	CLAMP	3				
9	90465-13275	CLAMP	7				
10	90464-13073	CLAMP	3				
11	90464-16061	CLAMP	2				
12	90464-15195	CLAMP	1				
13	90465-13152	CLAMP	5				
14	90464-23041	CLAMP	1				
15	5TJ-82590-E0	WIRE HARNESS ASSY	1				
16	5TJ-81980-00	.DIODE ASSY	1				
17	4WA-81980-00	.DIODE ASSY	1				
18	5UM-81960-E0	RECTIFIER & REGULATOR ASSY	1				
19	5UM-21288-E0	GUIDE, CABLE	1				
20	90105-06110	BOLT, FLANGE	2				
21	5TJ-82100-01	BATTERY ASSY (YTZ7S)	1				
22	5UM-82176-E0	DAMPER	1				
23	8CY-82131-00	BAND, BATTERY	1				
24	5TJ-82115-00	WIRE, PLUS LEAD	1				
25	5TJ-82116-E0	WIRE, MINUS LEAD	1				
26	5TJ-81940-12	STARTER RELAY ASSY	1				
27	42X-82151-00	.FUSE (10A-BL)	2				

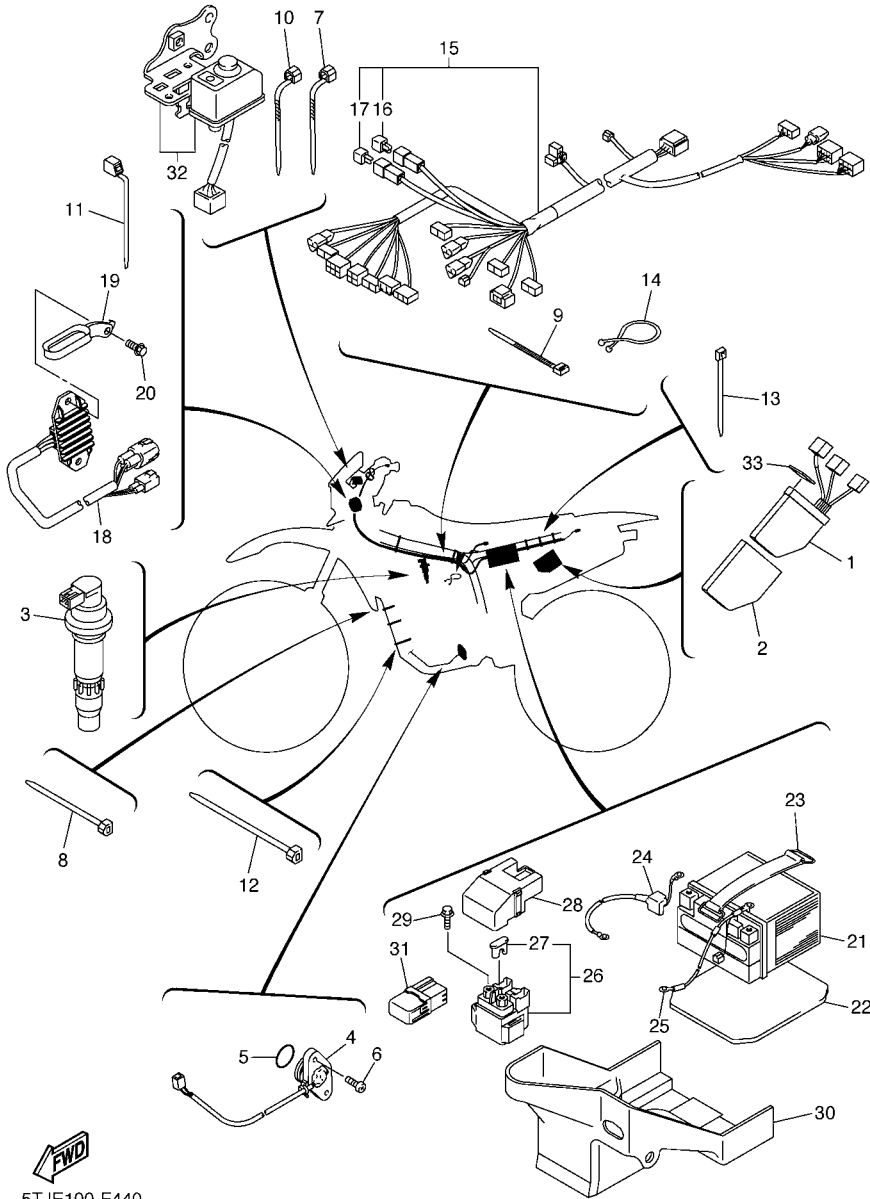

5TJE100-F440



5TJE100-F440

FIG. 44 ELECTRICAL 1

REF. NO.	PART NO.	DESCRIPTION	5TJM				REMARKS
28	5SL-82119-10	COVER, LEAD WIRE	1				
29	95022-06008	BOLT, FLANGE	2				
30	5UM-81952-E0	HOLDER, RELAY	1				
31	5UM-81950-E0	RELAY ASSY	1				
32	5UM-82510-E1	MAIN SWITCH ASSY	1				
33	5UM-8235Y-E0	DAMPER	1				

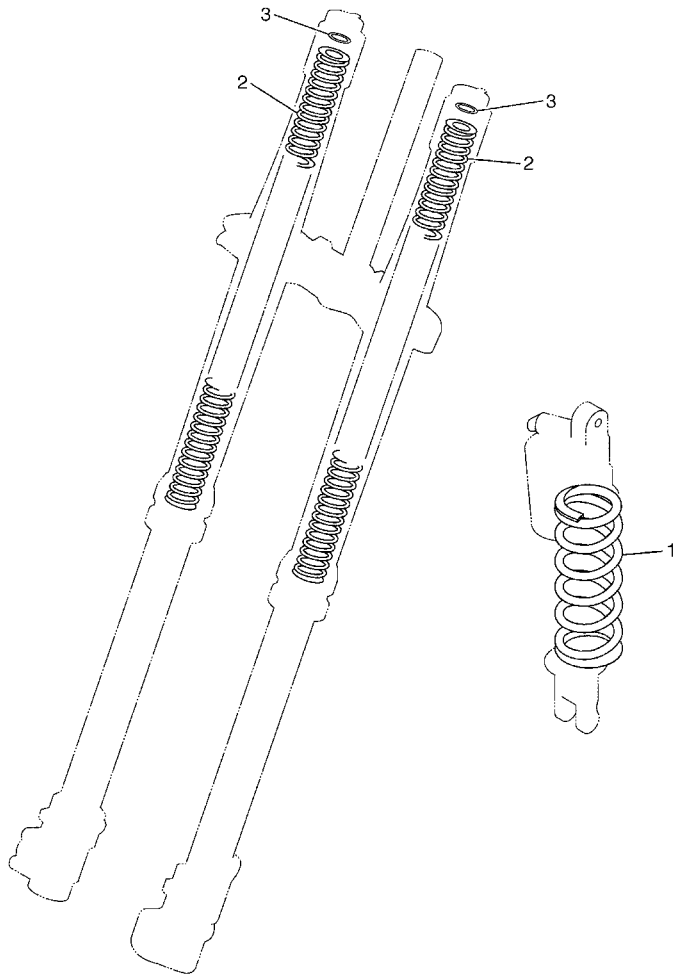

FIG. 45 ALTERNATE FOR CHASSIS

REF. NO.	PART NO.	DESCRIPTION	QTY	UNIT	REMARKS
1	5UN-22212-00	SPRING (K=42N/MM)	1		AP
	5UN-22212-10	SPRING (K=44N/MM)	1		AP
	5UN-22212-20	SPRING (K=46N/MM)	1		AP
	5UN-22212-30	SPRING (K=48N/MM)	1		AP
	5UN-22212-40	SPRING (K=50N/MM)	1		AP
	5UN-22212-50	SPRING (K=52N/MM)	1		AP
	5UN-22212-70	SPRING (K=56N/MM)	1		AP
2	5TJ-23141-00	SPRING (K=4.0N/MM)	1		AP
	5TJ-23141-10	SPRING (K=4.1N/MM)	1		AP
	5TJ-23141-20	SPRING (K=4.2N/MM)	1		AP
	5TJ-23141-30	SPRING (K=4.3N/MM)	1		AP
	5TJ-23141-40	SPRING (K=4.4N/MM)	1		AP
	5TJ-23141-60	SPRING (K=4.6N/MM)	1		AP
3	5XE-23364-00	COLLAR 2	1		AP



5XC1100-C390

NUMERICAL INDEX

PART NO.	GRID NO.	PART NO.	GRID NO.	PART NO.	GRID NO.	PART NO.	GRID NO.	PART NO.	GRID NO.	PART NO.	GRID NO.
5TJ-11101-10	B - 2	3LD-12168-M1	B - 4	5TA-13440-00	B - 11	5UM-14462-E0	B - 13	5XC-14922-00	C - 3	2S2-15155-10	C - 6
5TJ-11126-00	B - 13	3LD-12168-R1	B - 4	5BE-13447-20	B - 11	5TJ-14475-00	B - 12	5GS-14933-00	C - 3	3Y1-15363-00	C - 8
5TA-11133-10	B - 2	3LD-12168-U1	B - 4	2S2-13597-00	B - 12	5JG-14521-00	B - 15	5GS-14933-40	C - 2	2S2-1536A-00	C - 6
5TA-11134-10	B - 2	3LD-12168-W1	B - 4	5TJ-14101-E0	B - 14	5JG-14522-00	B - 14	5TA-14934-00	C - 3	5XC-15373-00	C - 6
5TJ-11166-10	B - 2	3LD-12168-Y1	B - 4	5NL-14105-00	C - 2	5JG-14531-00	C - 3	5GS-14940-00	C - 3		
3P6-11167-00	B - 2	3LD-12169-11	B - 4	4MX-14115-00	C - 3	3TJ-14536-40	C - 2	5JG-14940-17	C - 2	4JT-15381-01	C - 6
5TJ-11167-10	B - 13	3LD-12169-31	B - 5	3TJ-14137-40	B - 12	5JG-14546-01	B - 14	5JG-14940-18	C - 2	5BE-15383-01	C - 6
2S2-11181-00	B - 2	3LD-12169-50	B - 5		C - 3	676-14548-00	C - 2	5JG-14940-19	C - 2	2S2-15388-00	C - 6
2S2-11190-10	B - 2	3LD-12169-70	B - 5	5BE-14146-00	C - 3	4MX-14561-00	C - 3	5TA-14943-15	B - 15	5TJ-15411-30	C - 8
2S2-11193-00	B - 2	3LD-12169-90	B - 5	5PA-14146-00	C - 3	6H4-14561-00	C - 2	4MX-14943-40	B - 15	5TA-15415-20	C - 8
5UM-1119E-00	B - 2	3LD-12169-E0	B - 5	5TA-14155-00	C - 2	5NX-14562-00	C - 3	4MX-14943-41	B - 15	2S2-15421-10	C - 6
2S2-11311-10	B - 2	3LD-12169-G0	B - 5	633-14159-00	C - 2	3TJ-14564-40	C - 3	4MX-14943-42	B - 15	2S2-15431-00	C - 8
2S2-11351-00	B - 2	3LD-12169-J0	B - 5	3TJ-14159-40	B - 14	5JG-14565-00	C - 3	4MX-14943-43	B - 15	5TA-15441-01	C - 7
5TJ-11400-20	B - 3	3LD-12169-L0	B - 5	5XC-14171-00	C - 2	5TJ-14591-10	C - 3	4MX-14943-44	B - 15	2S2-15451-00	C - 8
5TJ-11412-20	B - 3	3LD-12169-N0	B - 5	3TJ-14191-40	C - 2	688-14592-00	B - 14	4MX-14943-90	B - 15	5TA-15453-00	C - 8
2S2-11422-00	B - 3	3LD-12169-T0	B - 5	5UL-14196-00	C - 3	5TJ-14611-10	C - 5	4MX-14943-91	B - 15	2S2-15462-10	C - 8
2S2-11454-00	B - 3	5TJ-12170-00	B - 6	5TA-14197-00	C - 3	3VD-14613-01	C - 5	4MX-14943-92	B - 15	5TJ-1549B-20	C - 8
2S2-11455-00	B - 3	5TJ-12180-30	B - 6	2S2-14208-00	C - 2	5TJ-14623-00	C - 5	4MX-14943-93	B - 15	5TG-15515-01	C - 11
2S2-11464-00	B - 3	5TA-12210-10	B - 6	5NX-14216-00	C - 3	5TA-14628-00	C - 5	4MX-14943-94	B - 15	5TJ-15517-00	C - 11
2S2-11531-00	B - 3	4FM-12213-00	B - 6	5TA-14227-00	B - 12	5TJ-14710-E0	C - 5	5TJ-14947-00	B - 15	4GY-15521-00	C - 11
2S2-11536-00	B - 3	5BE-12241-00	B - 2	5TA-14239-00	B - 12	5PH-14714-00	C - 5	4MX-14948-05	B - 15	5TJ-15560-20	C - 11
5JG-11603-00	B - 3	2S2-12251-00	B - 6	5TA-14261-00	C - 3	5BE-14747-00	C - 5	4MX-14948-06	B - 15	5UM-15570-00	C - 11
2S2-11631-20	B - 3	5TA-12252-00	B - 6	5JG-14264-00	B - 15	4BD-14766-00	C - 5	4MX-14948-07	B - 15	5VY-15586-00	C - 11
5TA-11633-00	B - 3	5TJ-12299-00	B - 6	3TJ-14267-40	B - 14	5TJ-14780-00	C - 5	4MX-14948-08	B - 15	2S2-15601-00	C - 10
2S2-11651-00	B - 3	5TJ-1240A-E0	B - 8	5JG-14275-00	B - 15	5TJ-14784-00	C - 5	4MX-14948-09	B - 15	2S2-15620-01	C - 10
5TG-11681-00	B - 3	5BE-12422-20	B - 7	5TJ-14291-00	B - 12	5BE-14788-00	C - 5	4JT-1494F-01	B - 15	5XD-15621-00	C - 10
5TA-12111-00	B - 4	5BE-12439-00	B - 7	5TA-14293-00	B - 12	5TJ-14799-00	C - 5	4JT-1494F-03	C - 2	5TA-15651-00	C - 10
5TA-12112-00	B - 4	5UM-1244J-E0	D - 6	3TJ-14293-40	C - 2	5UM-14803-00	C - 4	4JT-1494F-05	C - 2	5GR-15664-00	C - 10
5TJ-12113-00	B - 4	5DJ-12451-00	B - 7	5TA-14335-00	C - 2	5TJ-14815-00	C - 4	4JT-1494F-07	C - 2	5SG-15668-00	C - 10
5TJ-12114-00	B - 4	5GR-12458-00	B - 7	5JG-14346-00	C - 3	5TJ-14834-E0	C - 4	4JT-1494F-09	C - 2	2S2-15671-00	C - 10
4GY-12117-00	B - 4	2S2-12461-70	B - 8	5TA-14371-00	C - 2	5TJ-14871-10	C - 4	3TJ-1494F-11	B - 15	214-15686-00	C - 10
5BE-12117-00	B - 4	22W-12462-00	B - 8	5JG-14379-00	C - 2	5TJ-14881-10	C - 4	4JT-1494F-11	B - 15	2S2-16111-60	C - 12
1AA-12118-00	B - 4	2S2-12464-70	B - 8	2S2-14388-00	B - 14	5TJ-14882-10	C - 4	3TJ-1494F-12	B - 15	5XD-16150-60	C - 12
1WG-12118-00	B - 4	2S2-12481-00	B - 8	4MX-14392-00	C - 2	5TJ-14916-91	B - 14	3TJ-1494F-13	B - 15	5XD-16154-00	C - 12
33M-12119-00	B - 4	1C3-12482-00	B - 8	5UM-14401-E0	B - 12	5TJ-14916-9M	B - 14	4JT-1494F-13	C - 2	5TA-16321-00	C - 12
4SV-12119-00	B - 4	2S2-12482-00	B - 8	5UM-14417-E0	B - 12	5TJ-14916-9N	B - 14	3TJ-1494F-14	B - 15	1TA-16325-00	C - 12
5TA-12121-00	B - 4	5BE-12564-00	B - 7	5TJ-14419-00	B - 13	5TJ-14916-9P	B - 14	3TJ-1494F-15	B - 15	4X7-16325-00	C - 12
3GM-12126-00	B - 4	2S2-12576-00	B - 8	5UM-1441A-E0	B - 13	5TJ-14916-9R	B - 14	5JG-14951-00	B - 14	5JG-16351-00	C - 12
3FV-12153-10	B - 5	2S2-12578-00	B - 8	5UM-1441G-E0	B - 12	5TJ-14916-9S	B - 14	5GS-14958-00	C - 3	5JG-16356-00	C - 12
3LD-12168-00	B - 4	5TJ-12579-E0	B - 8	5UM-14437-E0	B - 12	5TJ-14916-9T	B - 14	5JG-14959-00	B - 14	2S2-16357-00	C - 12
3LD-12168-20	B - 4	583-13113-00	C - 9	5UM-1443A-E0	B - 12	5TJ-14916-A1	B - 14	5JG-14984-00	C - 2	5TA-16371-10	C - 12
3LD-12168-40	B - 4	353-13115-01	B - 2	5BF-1443E-00	B - 13	5TJ-14916-AM	B - 14	4SR-14985-00	C - 2	5TJ-16381-20	C - 12
3LD-12168-60	B - 4	2S2-13300-10	B - 10	5NY-14442-00	B - 12	5TJ-14916-AN	B - 14	5TA-14987-00	B - 12	5TJ-17121-20	C - 13
3LD-12168-80	B - 4	5TA-13320-00	B - 10	5UM-14451-E0	B - 12	5TJ-14916-AP	B - 14	5TJ-14987-00	C - 3	5TJ-17131-20	C - 13
3LD-12168-A0	B - 4	2S2-13341-00	B - 10	5TJ-14453-E0	B - 12	5TJ-14916-AR	B - 14	5TA-14991-00	C - 2	5TJ-17141-20	C - 13
3LD-12168-F0	B - 4	2S2-13342-00	B - 10	5NY-14455-20	B - 12	5TJ-14916-AS	B - 14	4FN-14997-00	B - 14	5TJ-17151-20	C - 13
3LD-12168-H1	B - 4	5BE-13411-00	B - 10	5TJ-14458-00	B - 12	5TJ-14916-AT	B - 14	5TA-14997-00	C - 2	5TJ-17211-20	C - 13
3LD-12168-K1	B - 4	2S2-13412-00	B - 10	5TJ-14459-01	B - 12	5TJ-14916-NT	B - 14	2S2-15100-10	C - 6	5TJ-17221-20	C - 13

NUMERICAL INDEX

PART NO.	GRID NO.	PART NO.	GRID NO.	PART NO.	GRID NO.	PART NO.	GRID NO.	PART NO.	GRID NO.	PART NO.	GRID NO.
5TJ-17231-20	C - 13	3RV-21668-A0	D - 8	4JX-22226-00	D - 9	5XE-23393-L0	D - 11	1C3-25452-00	E - 4	5BE-26282-00	E - 7
5TJ-17241-20	C - 13	5UM-21711-E0	D - 6	3SP-22234-00	D - 9	5TJ-2339E-00	E - 14	5TJ-25452-80	E - 4	5SF-26287-10	E - 7
5TJ-17251-20	C - 13	5UM-21717-E0	D - 6	5NY-22241-00	D - 9	4EW-23416-00	D - 10	5CG-25715-00	E - 8	5UM-26302-E0	E - 7
2S2-17402-00	C - 13	5XC-21719-90	D - 6	5XE-22242-00	D - 9	5UM-23435-E1	D - 10		E - 10	5UM-26334-E0	F - 2
5TJ-17411-20	C - 13	5UM-21721-E0	D - 6	5MV-22253-00	D - 9	5XC-23441-90	D - 10	1C3-25718-50	E - 6	5TJ-26335-E0	E - 7
2S2-17466-00	C - 6	2S2-2172A-80	D - 6	1C3-22253-50	D - 9	5UM-23442-E0	D - 10	1C3-2580T-00	E - 3	5HD-26337-00	F - 2
2S2-17471-00	C - 14	5TJ-2172A-E0	D - 6	4AA-22259-40	D - 9	5XC-23466-L0	D - 12	1C3-2580W-71	E - 6	5TA-26339-00	F - 2
2S2-18101-00	D - 2	5UM-2172S-E0	D - 6	1P8-22355-00	D - 7	5XC-23467-L0	D - 12	2S2-2581T-70	E - 3	1C3-26342-50	E - 7
5XC-18110-00	D - 2	5UM-21730-E0	D - 6	4EW-22474-00	D - 9	5TJ-23525-C0	D - 12	5UN-25827-60	E - 6	5NY-26372-00	E - 8
5MW-18122-01	D - 2	5TJ-2173L-00	D - 6	3JE-22475-00	D - 9	5UM-23591-E0	E - 13	5UN-25828-60	E - 6	5TJ-26372-80	F - 2
2S2-18140-10	C - 15	5UM-2173S-E0	D - 6	5NY-22475-00	D - 9	5UM-24110-E1	D - 13	2S2-2582W-70	E - 6	2S2-27200-10	E - 9
5TJ-18172-00	D - 2	5UM-21740-E0	D - 6	5UN-22898-60	E - 6	4EW-2412F-00	D - 13	5MV-25833-00	E - 8	5UN-27217-00	E - 10
3XJ-18173-10	D - 2	5UM-2174A-E0	D - 6	1C3-22969-90	D - 7	5XE-24144-00	D - 13	1C3-2583V-00	E - 10	1C3-27217-10	E - 9
3XJ-18178-00	D - 2	5TJ-2174L-00	D - 6	5TJ-23102-F0	D - 11	5UM-24181-E0	D - 13	5DH-25849-00	E - 3	5UN-27218-00	E - 10
3XJ-18182-00	D - 2	5UM-2174T-E0	D - 5	5TJ-23103-F0	D - 11	5XC-24182-90	D - 13	5MV-25852-01	E - 8	5UN-27222-00	E - 10
3XJ-18184-00	D - 2	2TK-21757-00	B - 13	5TJ-23110-C0	D - 11	5XC-24183-90	D - 13	5UN-25852-50	E - 10	5UM-27311-E0	E - 9
2S2-18185-00	D - 2	5TJ-21757-00	B - 13	5XE-23111-L0	D - 11	3JD-24186-00	D - 13	5XE-25853-00	E - 8	5UM-27315-E0	E - 9
2S2-18501-00	C - 15	4XV-2177L-01	B - 12	5XE-23117-L0	D - 11	5XC-2419A-90	D - 13	5UN-25854-00	E - 10	5XC-27411-M0	E - 9
2S2-18502-00	C - 15	5UM-21860-E0	D - 6	5TJ-23120-C0	D - 11	5TJ-24311-E0	D - 13	5XE-25854-00	E - 8	5XC-27421-M0	E - 9
5BE-18503-00	C - 15	26H-21874-00	D - 6	5XE-23125-L0	D - 11	5XC-24339-90	D - 13	5UN-2585B-00	E - 10	1C3-27491-50	E - 6
5NL-18541-00	C - 15	26H-21875-00	D - 6	3JD-2312G-L0	D - 11	3XJ-24380-00	D - 13	5MV-25867-00	E - 8	5XC-28116-00	D - 4
278-18542-00	C - 15	2S2-22110-70	D - 7	5TJ-23136-C0	D - 11	5UM-24500-E0	D - 13	5NY-25868-00	E - 8	5TA-2814F-00	D - 4
2S2-18562-00	C - 6	5XC-22121-91	D - 8	5TJ-23141-00	F - 5	1P6-24512-00	D - 13	5TJ-25872-80	E - 8	5ET-28166-10	D - 4
5TJ-21101-E0	D - 3	1C3-22122-00	D - 8	5NY-24611-10	F - 5	5NY-24610-00	D - 13	5XC-25873-L0	E - 10	5UM-2831V-E0	D - 10
5UM-21190-E0	D - 3	2S2-22128-70	D - 7	5TJ-23141-20	F - 5	5UM-2470F-E0	D - 15	1C3-25875-50	E - 3	3FV-28386-00	B - 13
1C3-21244-10	D - 14	1C3-22141-10	D - 7	5TJ-23141-30	F - 5	5UM-24710-E0	D - 15	1C3-25876-50	E - 10	5TJ-81410-50	E - 11
5UM-21268-E0	D - 4	2S2-22151-70	D - 7	5TJ-23141-40	F - 5	5UM-24723-E0	D - 15	1C3-25886-50	E - 10	5TJ-81450-30	E - 11
5UM-21288-E0	F - 3	5UN-22176-00	D - 9	5TJ-23141-60	F - 5	5NY-25104-00	E - 2	5MV-2589F-00	E - 8	5TJ-81528-00	E - 11
1C3-2135F-00	D - 8	30X-22178-00	D - 3	5TJ-23141-L0	D - 11	5TJ-2510C-80	E - 2	5UN-25914-00	E - 6	5TJ-81801-00	E - 12
1C3-2139R-00	D - 8	3JD-22178-20	D - 3	5XE-23142-L0	D - 11	5NG-25111-50	E - 2	5DH-25914-50	E - 6	5TJ-81828-01	E - 12
2S2-21417-00	D - 4	5XC-2217A-90	D - 7	5XE-23144-L0	D - 11	5NY-25117-00	E - 2	3SP-25914-51	E - 3	5TJ-8183G-30	E - 12
2S2-21425-70	D - 3	5XC-2217F-90	D - 7	1C3-23145-L0	D - 11	1C3-25181-10	E - 2	5DH-25916-00	E - 3	50W-81846-M1	E - 12
2S2-21426-70	D - 3	4V4-22184-00	D - 3	5XE-23146-L0	D - 11	5GS-25304-00	E - 4		E - 6	5TJ-81890-30	E - 12
5UM-21447-E0	D - 3	5MV-22184-00	D - 9	1C3-2314F-M0	D - 11	5TJ-2530S-80	E - 5	3JD-25917-00	E - 3	5TJ-81940-12	F - 3
1C3-21448-10	D - 3	5UM-22199-E0	D - 7	5XE-23153-L0	D - 11	5ET-25311-00	E - 4		E - 6	5UM-81950-E0	F - 4
5XC-21456-90	D - 4	5TJ-22201-G0	D - 9	4SS-23158-L0	D - 11	5ET-25317-00	E - 4	5DH-25919-00	E - 3	5UM-81952-E0	F - 4
5UM-2147A-E0	D - 4	5TJ-22210-G0	D - 9	1C3-2315H-10	D - 12	4XM-25364-00	E - 4	5DH-25919-50	E - 6	5UM-81960-E0	F - 3
5TJ-21485-E0	D - 4	5UN-22212-00	F - 5	5TJ-2315J-C0	D - 12	1C3-25381-90	E - 5	8CR-25924-00	E - 6	4WA-81980-00	F - 3
5UM-21486-E0	D - 4	5UN-22212-10	F - 5	5TJ-2316A-F0	D - 11	1C3-25388-50	E - 5	3SP-25926-51	E - 3	5TJ-81980-00	F - 3
1C3-21511-51	D - 5	5UN-22212-20	F - 5	5UM-23170-E0	D - 11	1C3-25389-00	E - 5	5DH-25933-00	E - 3	5TJ-82100-01	F - 3
4XL-2153A-10	D - 12	5UN-22212-30	F - 5	5XE-23171-L0	D - 11	3JE-25394-00	E - 4	1UY-25937-51	E - 3	5TJ-82115-00	F - 3
5UM-2153E-00	D - 5	5UN-22212-40	F - 5	5DH-23183-00	D - 9	5SF-25394-00	E - 2		E - 6	5TJ-82116-E0	F - 3
4ES-2153E-01	D - 5	5UN-22212-50	F - 5	509-23184-L0	D - 9	1C3-25448-00	E - 4	5XC-26111-L0	E - 7	5SL-82119-10	F - 4
5PA-21568-00	D - 5	5UN-22212-60	D - 9	5TJ-2331E-80	D - 10	5GS-25448-50	E - 4	5XC-26124-90	E - 7	8CY-82131-00	F - 3
5UM-21610-E0	D - 5	5UN-22212-70	F - 5	5TJ-23340-M0	D - 12	1C3-25449-00	E - 4	5XC-26143-L0	E - 7	42X-82151-00	F - 3
5XE-21635-10	D - 5	3SP-22213-00	D - 9	3SP-23356-L0	D - 12	1C3-25450-00	E - 4	5TJ-26240-C0	E - 7	5UM-82176-E0	F - 3
5TJ-2163G-20	D - 5	5XE-22214-00	D - 9	5XE-23364-00	F - 5	5TJ-25450-80	E - 4	4GY-26241-00	E - 7	5TA-82310-10	F - 3
5TA-21642-00	D - 5	5MV-22224-00	D - 9	5TJ-23389-80	D - 10	1C3-25451-00	E - 4	5BE-26281-00	E - 7	5UM-8235Y-E0	F - 4

NUMERICAL INDEX

PART NO.	GRID NO.	PART NO.	GRID NO.	PART NO.	GRID NO.	PART NO.	GRID NO.	PART NO.	GRID NO.	PART NO.	GRID NO.
5UM-82510-E1	F - 4	90105-06064	D - 6	90110-08097	C - 5	90201-08043	D - 3	90340-14003	C - 8	90464-15152	F - 3
5TJ-82540-01	F - 3		E - 14	90111-06059	E - 10	90201-08044	E - 9	90340-27003	C - 8	90464-15195	F - 3
5TJ-82590-E0	F - 3	90105-06081	C - 6	90116-08022	B - 2	90201-08045	D - 3	90387-06009	D - 5	90464-16061	F - 3
5TJ-82911-80	F - 2		C - 14	90119-06146	D - 6	90201-08047	C - 10	90387-06065	B - 8	90464-23041	F - 3
5XD-82913-00	F - 2	90105-06100	D - 5	90119-06147	D - 5	90201-08048	E - 4		D - 13	90465-13152	F - 3
5TJ-82917-02	F - 2	90105-06103	D - 6	90119-06166	D - 4	90201-08061	C - 5	90387-06090	D - 5	90465-13275	D - 13
5XD-82946-00	F - 2	90105-06104	D - 7	90119-08095	D - 6	90201-08410	C - 3		D - 13		F - 3
5TJ-83500-F0	E - 13	90105-06105	C - 4	90149-05024	E - 11	90201-08512	B - 7	90387-06104	D - 10	90467-07138	C - 4
5UM-83519-E0	E - 13		D - 7	90149-05162	F - 2	90201-10025	B - 2	90387-08041	D - 3	90467-09006	C - 4
5UM-83595-E0	E - 13		E - 3	90149-06068	B - 10	90201-10032	E - 9	90387-08081	C - 5	90467-090A2	B - 8
5TJ-83755-C0	E - 13		E - 13	90149-06074	C - 6	90201-10045	D - 3	90387-086N4	D - 3		D - 6
5TJ-8375E-C0	E - 13	90105-06106	D - 5	90149-06083	B - 3		E - 9	90387-1003G	E - 9	90467-100A1	D - 13
5TJ-8375F-C0	E - 13	90105-06107	C - 4	90149-06108	D - 13	90201-105A8	C - 11	90387-124F4	D - 2	90467-140A4	C - 4
5TJ-83912-80	F - 2		D - 10	90149-10031	D - 3	90201-12020	E - 11	90387-14009	D - 8	90467-16063	F - 3
1C3-83922-50	E - 8		D - 13	90151-04003	D - 7	90201-12166	B - 10	90387-16010	D - 7	90467-160A4	B - 2
5TA-83941-00	F - 2		E - 6	90151-06051	E - 3	90201-125L6	C - 12	90387-18004	D - 7		B - 13
5HD-83951-00	F - 2	90105-06108	E - 6	90151-06071	C - 6	90201-127E1	D - 2	90387-18007	C - 6	90467-17089	B - 13
5UM-83976-E1	F - 2	90105-06110	E - 6	90152-06010	C - 10	90201-14020	D - 8	90387-18012	D - 7		C - 4
5UM-83976-F1	F - 2		E - 13	90154-05022	F - 3	90201-15701	C - 8	90387-20028	C - 13	90468-16001	E - 9
5LP-84126-10	F - 2		F - 3	90157-04005	E - 14	90201-16018	D - 7	90387-21005	C - 13	90480-12020	E - 14
5UM-84310-E1	E - 14	90105-06111	B - 8	90159-06092	C - 12	90201-162H4	C - 10	90387-2513F	C - 14	90480-14012	E - 13
5VM-84314-00	E - 14		D - 13	90170-10405	B - 3	90201-167P7	C - 10	90387-28012	C - 13	90480-15528	B - 8
5UM-84330-E0	E - 14		E - 6	90170-14171	B - 3	90201-20020	E - 5	90401-10172	E - 8	90480-18549	D - 13
5BF-84334-00	E - 14	90105-06127	D - 5	90170-20327	C - 12	90201-203E7	C - 13		E - 10	90501-043E0	C - 9
5UM-84340-E1	E - 14	90105-08133	D - 3	90170-24003	D - 10	90201-20685	C - 10	90413-14001	B - 13	90501-052G5	D - 2
5UM-84710-E0	E - 15	90105-08134	D - 12	90179-06028	D - 7	90201-21014	D - 7	90430-06014	B - 2	90501-06022	C - 15
5UM-84716-E0	E - 15	90105-08137	C - 5	90179-08019	E - 5	90201-24016	D - 10		B - 6	90501-120A3	E - 14
5UM-84736-E0	E - 15		E - 3	90179-10658	D - 3	90201-253K0	C - 13		B - 7	90501-147A5	C - 10
5UM-84737-E0	E - 15	90105-08143	D - 4	90179-12657	E - 11	90201-286K9	D - 10		C - 7	90501-160A2	C - 10
5TJ-85540-F0	F - 3	90105-08154	D - 10	90179-16011	E - 2	90202-05193	D - 13	90430-08119	C - 6	90501-237L0	C - 12
5UM-85546-E0	F - 3	90105-08156	D - 3	90179-20001	C - 14	90202-08045	B - 14	90430-10005	E - 8	90506-16007	E - 9
5XC-85885-00	C - 3	90105-08307	C - 5	90179-20009	C - 12	90206-06090	C - 5		E - 10	90506-30005	E - 9
5NY-W0041-00	E - 8		D - 3	90179-28003	D - 10	90208-25045	C - 12	90430-10188	C - 6	90508-26021	C - 15
5UN-W0042-50	E - 10	90105-10163	B - 2	90183-060A6	B - 8	90209-16011	D - 7	90445-082K4	C - 4	90508-28015	E - 9
5MV-W0045-01	E - 3	90105-10176	D - 3	90185-08008	E - 4	90209-21332	C - 13	90445-09220	D - 13	90508-28018	E - 9
1C3-W0046-B0	E - 6	90105-10189	D - 3	90185-08009	D - 3	90209-26348	C - 13	90445-09251	D - 13	90508-29021	D - 2
3JD-W0047-00	E - 3	90105-10191	D - 3	90185-10012	D - 9	90215-10009	B - 3	90445-14009	B - 10	90508-305B0	C - 10
5UN-W0047-50	E - 6	90105-10193	D - 3	90185-10018	E - 9	90215-14287	B - 3	90445-217G3	E - 9	91312-06012	B - 8
1UY-W0048-50	E - 3	90109-06034	F - 2	90185-14010	D - 8	90215-20005	C - 12	90450-17001	B - 10	91312-06020	B - 11
	E - 6	90109-06198	C - 15	90185-16002	D - 7	90215-21003	C - 14	90450-22001	B - 8		B - 12
5UN-W0057-00	E - 3	90109-06245	B - 13	90185-20002	E - 5	90240-08120	E - 9	90450-25001	B - 8	91312-06030	B - 10
5UN-W0057-50	E - 6	90109-08078	E - 4	90201-05021	E - 13	90240-10004	E - 9	90450-28001	B - 8		C - 6
5XE-W2587-10	E - 8	90109-10026	E - 9	90201-06013	C - 15	90249-05004	B - 13	90450-57010	B - 12	91312-06050	C - 6
90101-06041	D - 2	90110-05038	B - 12	90201-06032	D - 5	90249-05005	B - 13	90450-61002	B - 12	91312-06060	C - 6
90101-06044	C - 10	90110-05041	C - 5	90201-06084	D - 5	90280-03006	B - 3	90461-10136	C - 7	91312-06065	B - 11
90101-08006	E - 5	90110-06228	B - 11	90201-06570	D - 13	90282-05034	B - 3	90464-11M18	E - 15	91312-06080	C - 6
90105-05016	D - 10	90110-06248	E - 11	90201-06571	B - 9	90338-07043	B - 12	90464-13073	F - 3	91314-06016	C - 4
90105-06027	B - 2	90110-08087	C - 10		D - 5	90340-12007	B - 2	90464-13077	F - 3	91316-04012	B - 14

NUMERICAL INDEX

PART NO.	GRID NO.	PART NO.	GRID NO.	PART NO.	GRID NO.	PART NO.	GRID NO.	PART NO.	GRID NO.	PART NO.	GRID NO.
91402-20012	E - 9	93306-00105	B - 7	94591-57118	B - 6	99009-22500	C - 8				
91402-25015	E - 9	93306-00426	C - 13	94681-76021	E - 5	99009-45500	E - 4				
91808-16023	B - 2	93306-00431	C - 13	94701-00411	B - 2	99530-08012	B - 10				
91812-16001	C - 8	93306-07202	E - 4	95022-06008	F - 4	99530-08016	C - 8				
91A20-05140	B - 8	93306-20532	C - 13	95022-06010	B - 2	99530-10114	B - 10				
92012-05008	C - 5	93306-205A5	C - 13	95022-06012	B - 8		C - 6				
	E - 13	93306-27212	E - 4		C - 7	99530-14016	C - 6				
92012-05012	F - 2	93306-30633	B - 3	95022-06016	C - 7	9Y58A-76113	E - 5				
92012-06010	B - 8	93306-80501	C - 15		C - 8						
92012-06012	E - 13	93306-90409	E - 2	95022-06020	C - 8						
92902-06600	E - 13	93306-90509	C - 15		D - 2						
92902-08200	D - 4	93310-212R6	C - 11	95022-06025	B - 6						
92902-10200	D - 9	93310-63417	B - 3		E - 12						
	D - 10	93315-32166	D - 7	95022-06030	B - 7						
93101-14164	C - 8	93315-32269	D - 7		B - 10						
93102-12106	B - 7	93317-11287	C - 12		C - 8						
93102-12224	C - 12	93317-22262	D - 7	95022-06035	B - 2						
	D - 2	93332-00068	D - 10	95022-06040	C - 8						
93102-20108	C - 10	93332-00081	D - 10	95022-06080	C - 9						
93102-26468	E - 2	93340-21505	C - 12	95022-08040	D - 3						
93102-32480	C - 14	93342-22217	D - 7	95022-10016	C - 6						
93105-47007	E - 13	93410-20038	C - 10	95602-05100	F - 2						
93106-22002	D - 7	93420-18082	B - 3	95602-10200	D - 9						
93106-30001	E - 4	93440-10085	C - 12		D - 10						
93106-30045	E - 4	93440-10153	B - 10	95701-06500	E - 8						
93109-11073	B - 7	93440-25084	C - 13	95702-05500	E - 13						
93109-22019	D - 8	93440-28062	C - 13	95702-06500	D - 12						
93109-25001	D - 7	93440-41178	B - 6	95702-08500	B - 2						
93109-28043	D - 7	93503-08007	C - 9	95822-08016	C - 6						
93210-07135	B - 11	93507-32009	C - 10	97002-05016	F - 2						
93210-08003	C - 8	93511-32027	C - 12	97602-04110	C - 3						
93210-09165	C - 7	93603-16219	B - 10	97702-40010	E - 13						
93210-10197	C - 6	93604-10011	B - 7		E - 15						
93210-11073	E - 9	93608-33002	D - 2	97702-50016	E - 15						
93210-14369	C - 8	93612-16254	B - 2	97702-50516	B - 12						
93210-16500	B - 8	9383E-13233	C - 14		E - 14						
93210-17570	C - 10	9383E-14215	C - 14	97702-60016	D - 5						
93210-19123	C - 8	94108-21015	E - 2	98502-05010	E - 10						
93210-19758	B - 7	94109-21009	E - 2	98502-05020	E - 7						
93210-21001	F - 3	94111-18012	E - 4	98502-06025	C - 6						
93210-22164	C - 14	94113-18015	E - 4	98702-06025	D - 13						
93210-25711	E - 12	94212-18188	E - 4	98706-04012	E - 8						
93210-27370	C - 8	94213-18012	E - 4	98980-06008	C - 5						
93210-44678	E - 12	94227-21101	E - 2	99002-04600	B - 13						
93210-47675	B - 11	94309-18146	E - 4	99009-12400	B - 10						
93210-58346	C - 8	94309-21161	E - 2	99009-16400	C - 10						
93300-60839	D - 3	94416-21018	E - 2	99009-20400	C - 10						
93304-20310	B - 3	94421-18008	E - 4	99009-20500	C - 12						